

Fig. Pos.	Part No.	Description	Q'ty	Remark/Normteil/Maß	Baugruppe	Figure/Bild
1	1	2Y0-11101-00-R4	1	black	Cylinder Head/Zylinder-Kopf	1
1	2	583-11133-11	2			
1	3	91830-24016	2			
1	4	93210-14299	2			
1	5	583-11127-00	2			
1	6	90179-10279	4			
1	7	90179-10277	1			
1	8	90201-10124	5			
1	9	95303-08600	2			
1	10	90201-08649	2			
1	11	91316-06055	2			
1	12	1E6-17841-00	1			
1	13	93104-08055	1			
1	14	90201-08587	2			
1	15	1E6-17843-00	1			
1	16	90109-06418	1			
1	17	90430-06014	1			
1	18	91316-06025	3			
1	19	1T1-11197-00	1			
1	20	90340-14038	2			
1	21	90430-14043	2			
1	22	583-11186-00-R4	2	black		
1	23	93210-49296	2			
1	24	91316-06018	4			
1	25	94701-00117	1			
1	26	583-12288-00	1			
1	27	90508-16303	1			
1	28	90109-06418	1			
1	29	90430-06014	1			
1	30	583-12283-00	1			
1	31	93104-12054	1			

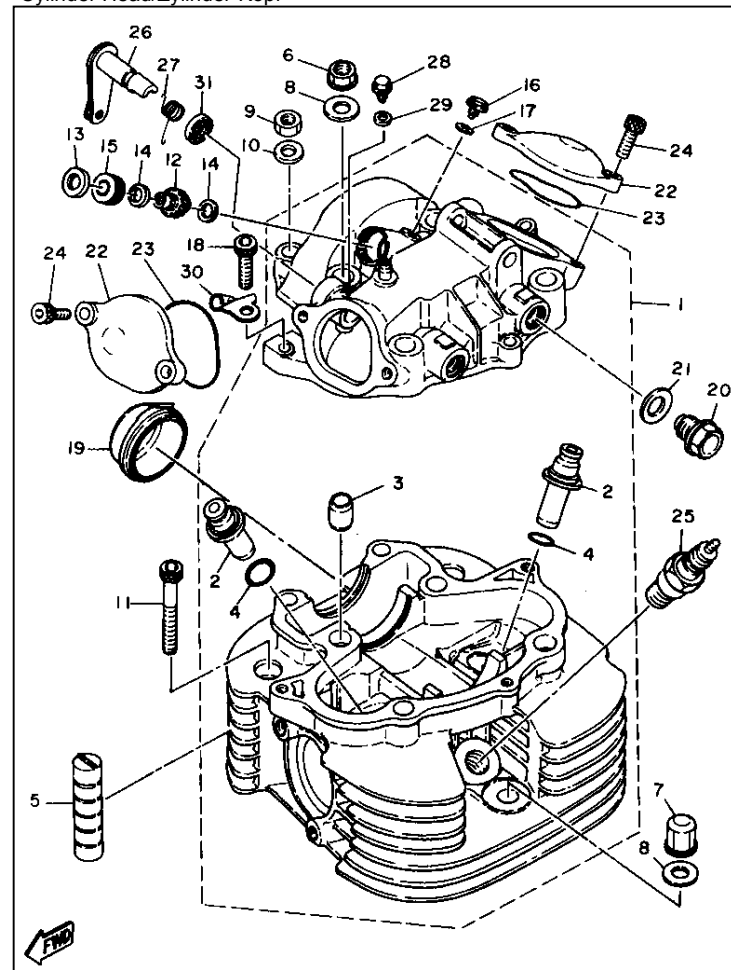

Fig. Pos.	Part No.	Description	Q'ty	Remark/Normteil/Maß	Baugruppe	Figure/Bild
-----------	----------	-------------	------	---------------------	-----------	-------------

2	1	583-11310-00	1		Cylinder/Zylinder	2
2	2	93210-92295	1			
2	3	583-11127-00	2			
2	4	90201-10590	4			
2	5	91830-24016	2			
2	6	583-11351-00	1			
2	7	90116-10087	4			
2	8	90179-10201	4			
2	9	91316-06030	3			
2	10	583-11181-01	1			
2	11	91830-24016	2			
2	12	90116-10222	2			
2	13	90116-10223	1			
2	14	90116-08190	2			
2	15	90116-10225	2			

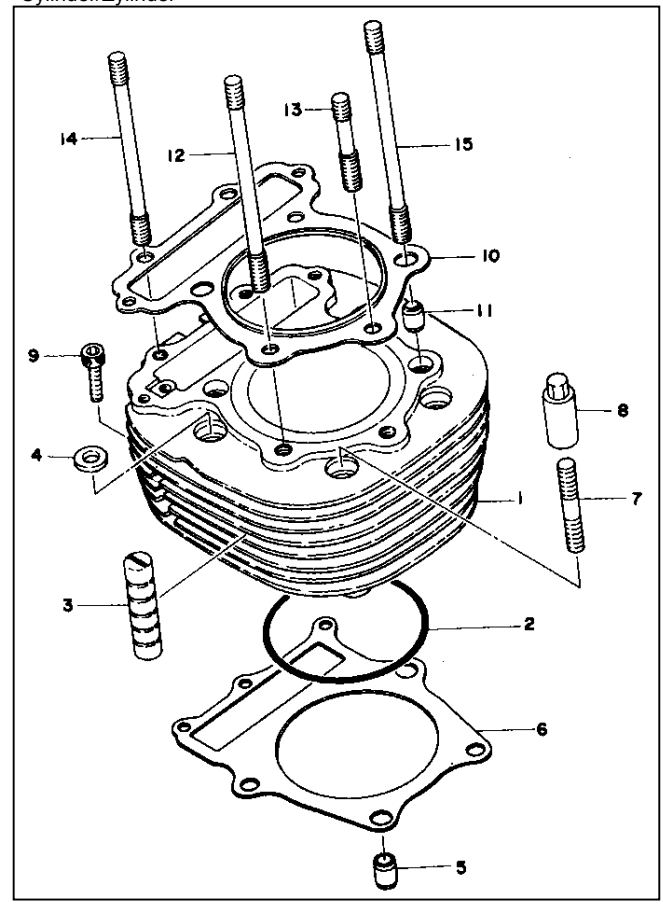

Fig. Pos.	Part No.	Description	Q'ty	Remark/Normteil/Maß	Baugruppe	Figure/Bild
3	1	583-11400-00	1	CRANKSHAFT ASSY	Crankshaft & Piston/Kurbelwelle & Kolben	3
3	2	583-11412-00	1	CRANK 1		
3	3	583-11422-00	1	CRANK 2		
3	4	583-11681-00	1	PIN, crank 1		
3	5	93310-635A5	1	BEARING, cylindrical		
3	6	583-11651-00	1	-ROD, connecting		
3	7	93306-30622	1	BEARING (6306SH4 SPECIAL)		
3	8	93102-30145	1	OIL SEAL		
3	9	90280-05013	1	KEY, woodruff		
3	10	90201-12593	1	WASHER, plate		
3	11	92901-12100	1	WASHER, spring		
3	12	90170-12067	1	NUT		
3	13	93306-30702	1	BEARING (B6307)		
3	14	583-11150-00	1	BREAKER SHAFT ASSY		
3	15	583-11536-00	1	GEAR, drive (21T)		
3	16	90201-15234	1	WASHER, plate		
3	17	90201-09572	1	WASHER, plate		
3	18	583-11631-02-95	1	PISTON (STD)		
3	18a	583-11631-02-96	1	PISTON (STD)		
3	18b	583-11635-02	1 AP	PISTON (1ST O/S 0.25MM)		
3	18c	583-11636-02	1 AP	PISTON (2ND O/S 0.50MM)		
3	18d	583-11637-02	1 AP	PISTON (3RD O/S 0.75MM)		
3	18e	583-11638-02	1 AP	PISTON (4TH O/S 1.00MM)		
3	19	583-11610-01	1	PISTON RING SET (STD)		
3	19a	583-11610-11	1 AP	PISTON RING SET (1ST O/S)		
3	19b	583-11610-21	1 AP	PISTON RING SET (2ND O/S)		
3	19c	583-11610-31	1 AP	PISTON RING SET (3RD O/S)		
3	19d	583-11610-41	1 AP	PISTON RING SET (4TH O/S)		
3	20	583-11633-00	1	PIN, Piston		
3	21	93450-22027	1	CIRCLIP		

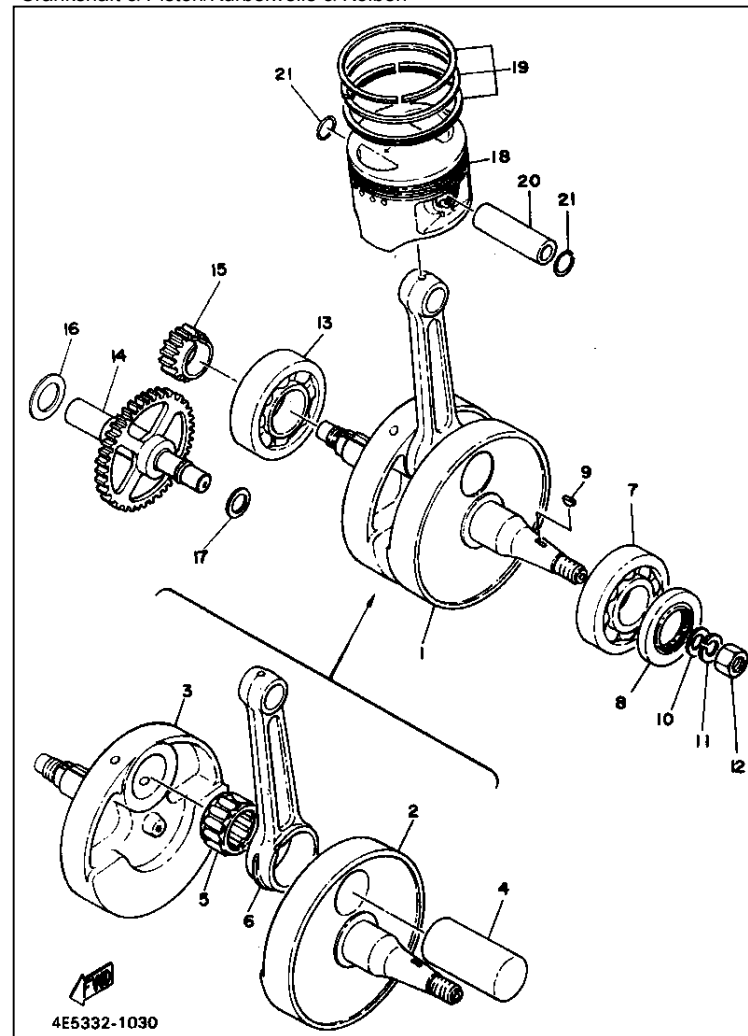

Fig. Pos.	Part No.	Description	Q'ty	Remark/Normteil/Maß	Baugruppe	Figure/Bild
4	1	212-12111-01	1		Valve/Ventile	4
4	2	583-12121-00	1			
4	3	90501-31454	2			
4	4	90501-44455	2			
4	5	256-12116-01	2			
4	6	341-12119-02	2			
4	7	256-12117-02	2			
4	8	341-12118-00	4			
4	9	583-12151-00	2			
4	10	583-12156-01	2			
4	11	583-12159-00	2	Vierkant		
4	11a	4X7-12159-00	2	Inbus		
4	12	90170-08173	2			

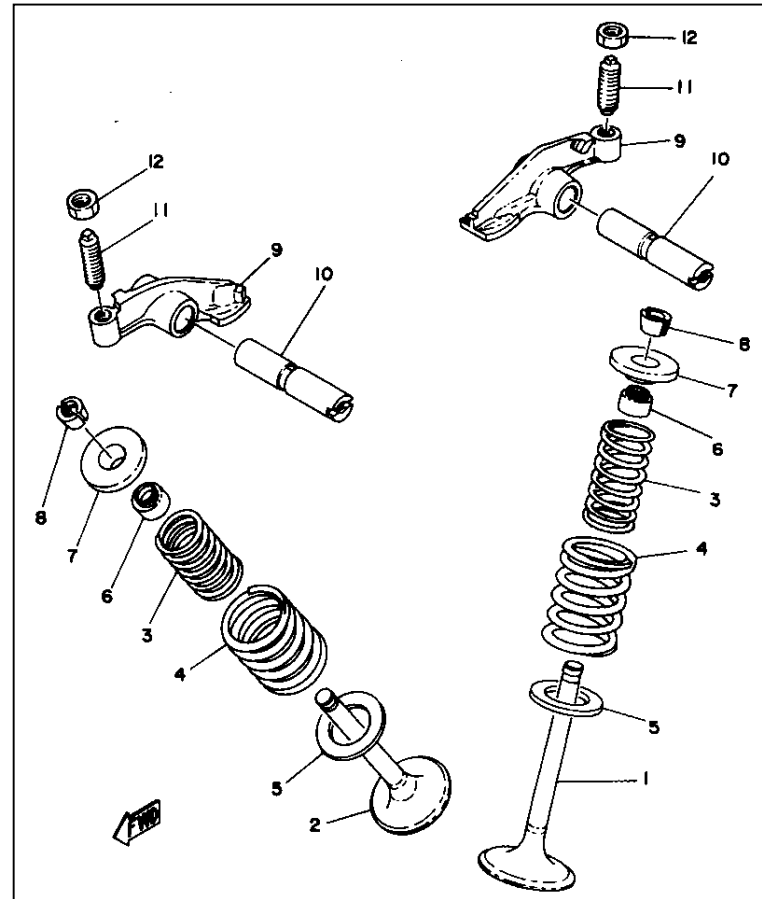

Fig. Pos.	Part No.	Description	Q'ty	Remark/Normteil/Maß	Baugruppe	Figure/Bild
5	1	683-12171-01	CAMSHAFT 1	1	Camshaft & Chain/Nockenwelle & Steuerkette	5
5	2	583-12176-00	SPROCKET, cam chain (34T)	1		
5	3	93604-16092	PIN, dowel	1		
5	4	90101-10303	BOLT	1		
5	5	1T1-12279-00	PLATE	1		
5	6	90201-10591	WASHER, plate	1		
5	7	93306-00502	BEARING (B6005)	1		
5	8	93306-00506	BEARING (B6005)	1		
5	9	93440-47044	CIRCLIP	1		
5	10	583-11549-00	SPROCKET, cam chain (17T)	1		
5	11	583-11533-00	PLATE, cam chain sprocket	1		
5	12	94500-02106	CHAIN (BFOSM-106L)	1		
5	13	94600-02001	JOINT, chain	1		
5	14	583-12231-00	GUIDE, stopper 1	1		
5	15	92501-06014	SCREW, pan head	2		
5	16	341-12241-03	GUIDE, stopper 2	1		
5	17	583-12247-00	SHAFT, tensioner	1		
5	18	93210-12152	O-RING	1		
5	19	583-12217-00	ROD, chain tensioner	1		
5	20	90501-14095	SPRING, compression	1		
5	21	2H0-12232-00	DAMPER	1		
5	22	90149-18100	SCREW	1		
5	23	90179-18199	NUT	1		
5	24	93210-32172	O-RING	1		
5	25	583-12212-00	CAP, chain tensioner	1		

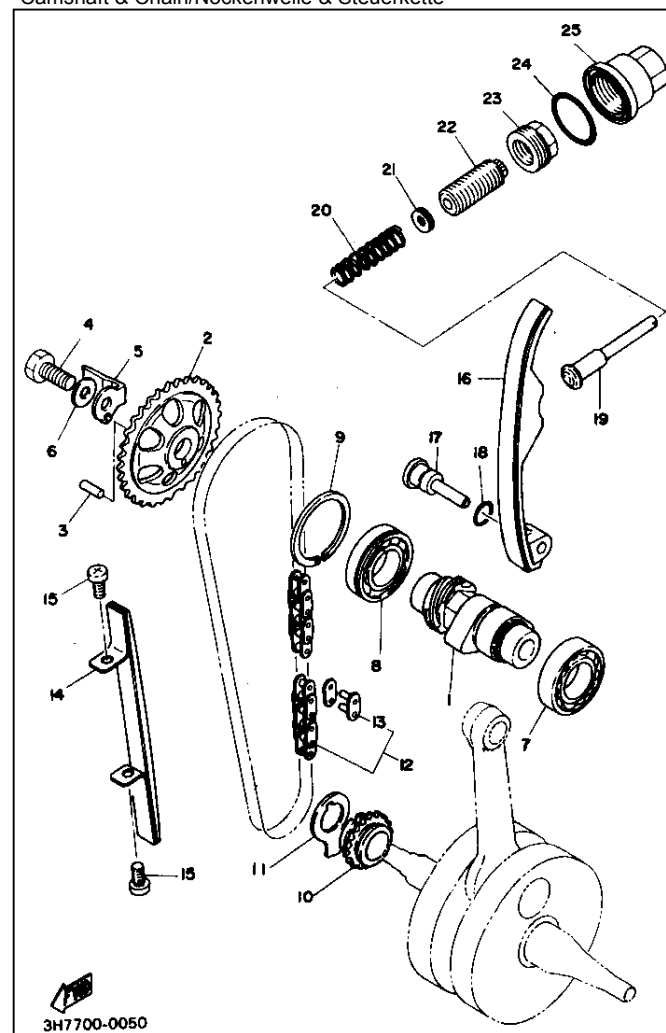

Fig. Pos.	Part No.	Description	Q'ty	Remark/Normteil/Maß
6	1	583-13324-00	GEAR, drive (42T)	1
6	2	683-13325-00	GEAR, pump driven (41T)	1
6	3	583-13314-00	SHAFT, pump	1
6	4	93603-17070	PIN, dowel	2
6	5	90201-10119	WASHER, plate	1
6	6	93410-10025	CIRCLIP	1
6	7	90201-12166	WASHER, plate	1
6	8	583-13316-02	COVER, pump	1
6	9	92501-06030	SCREW, pan head	3
6	10	92501-06018	SCREW, pan head	2
6	11	93104-11038	OIL SEAL	2
6	12	583-13336-02	HOUSING, rotor	1
6	13	93604-22050	PIN, dowel	2
6	14	583-13310-01	rotor ASSY 1	1
6	15	583-13320-00	rotor ASSY 2	1
6	16	583-13411-00	STRAINER, oil	1
6	17	583-13414-00	GASKET, strainer cover	1
6	18	583-13417-01	COVER, strainer	1
6	19	91316-06020	BOLT	6
6	20	11H-13455-00	PLUG	1
6	21	98901-06008	SCREW, bind	1
6	22	214-11198-01	GASKET	1
6	23	4X7-13440-90	ELEMENT ASSY, oil cleaner	1
6	24	583-13447-00	COVER, oil element	1
6	25	93210-64297	O-RING	1
6	26	91316-06060	BOLT	2
6	27	90109-06511	BOLT	1
6	28	93210-07135	O-RING	1
6	29	90149-05110	SCREW	1
6	30	90430-05126	GASKET	1
6	31	683-13113-00	SEAT, check ball	1
6	32	93503-08007	BALL	1
6	33	90501-05378	SPRING, compression	1
6	34	583-13161-01	PIPE, delivery 1	1
6	35	90401-08038	BOLT, union	2
6	36	90430-08119	GASKET	4
6	37	583-13464-;-00	HOSE, oil 1	1
6	38	93210-10197	O-RING	1
6	39	91316-06015	BOLT	2
6	40	91316-06012	BOLT	1

Baugruppe Oil Pump & Oil Cleaner/Öl-Pumpe & -Filter Figure/Bild 6

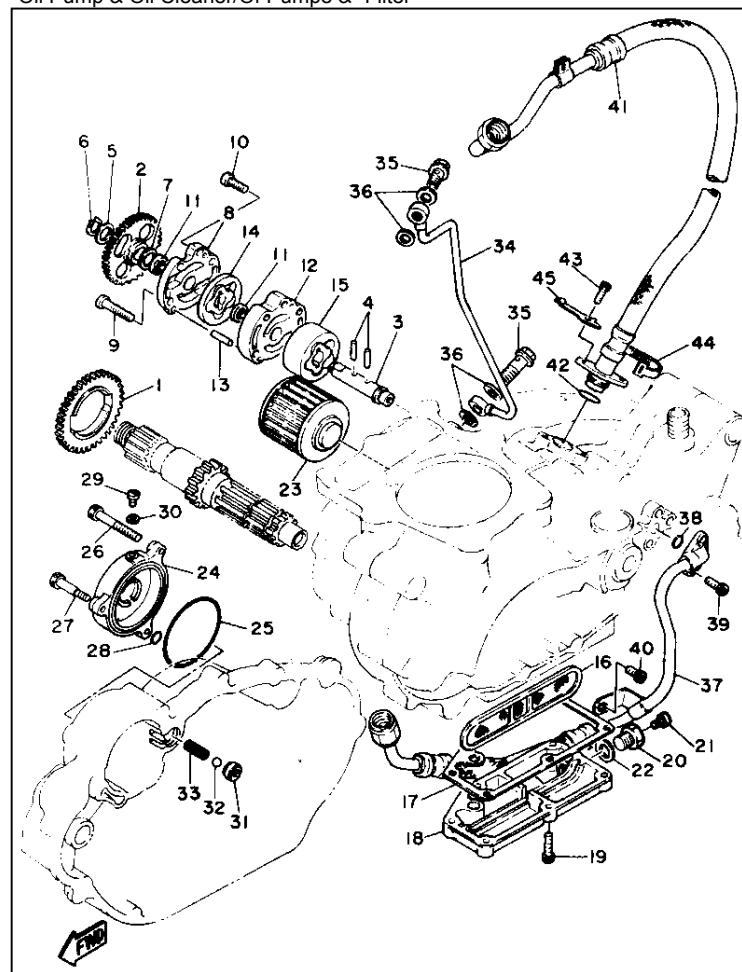

Fig. Pos.	Part No.	Description	Q'ty	Remark/Normteil/Maß	Baugruppe	Figure/Bild
6 41	583-13465-02	HOSE, oil 2	1			
6 42	93210-15171	O-RING	1			
6 43	91316-06015	BOLT	2			
6 44	437-83936-00	BAND, switch cord	1			
6 45	90465-06077	CLAMP	1			

Fig. Pos.	Part No.	Description	Q'ty	Remark/Normteil/Maß
7 1	1U6-13565-01	JOINT, carburetor	1	
7 2	256-13564-00	COVER, manifold	1	
7 3	583-13556-01	GASKET, manifold	1	
7 4	91316-06020	BOLT	2	
7 5	90460-58124	CLAMP, hose	1	
7 6	583-14411-01	CASE, air cleaner 1	1	
7 7	583-14422-00	CAP, cleaner esse 2	1	
7 8	98601-06012	SCREW, pan head	3	
7 9	92901-05100	WASHER, spring	3	
7 10	92901-05600	WASHER, plate	3	
7 11	583-14421-00	CASE, air cleaner 2	1	
7 12	97301-06020	BOLT	2	
7 13	92901-06100	WASHER, spring	2	
7 14	92901-06600	WASHER, plate	2	
7 15	583-14451-09	ELEMENT, air cleaner	1	
7 16	583-14468-01	PLATE, element fitting	1	
7 17	583-14472-00	PLATE, element	1	
7 18	583-14437-00	DUCT	1	
7 19	583-14431-00	SILENCER, intake 1	1	
7 20	583-14441-00	SILENCER, intake 2	1	
7 21	583-14485-00	PIPE, joint	1	
7 22	583-14453-00	JOINT, air cleaner 1	1	
7 23	90460-58015	CLAMP, hose	1	
7 24	90460-61063	CLAMP, hose	1	
7 25	90480-14102	GROMMET	2	
7 26	90387-07391	COLLAR	2	
7 27	97301-06025	BOLT	2	
7 28	92901-06100	WASHER, spring	2	

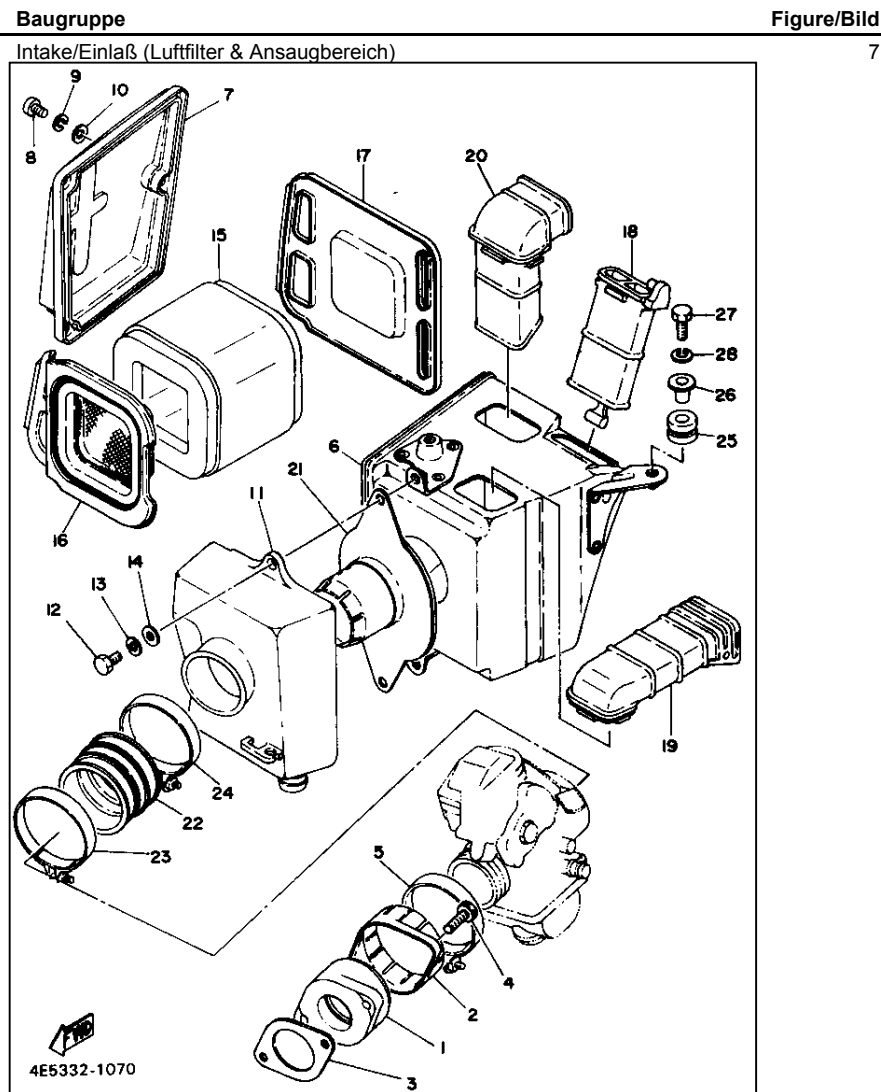

Fig. Pos.	Part No.	Description	Q'ty	Remark/Normteil/Maß	Baugruppe	Figure/Bild
8	1	1T2-14101-61	1		Carburetor/Vergaser	8
8	2	193-14142-25	1			
8	3	583-14141-52	1			
8	4	583-14148-00	1			
8	5	137-14143-44	1	UR STD		
8	5a	137-14143-42	1	UR		
8	5b	137-14143-46	1	UR		
8	6	168-14190-28	1			
8	7	214-14195-00	1			
8	8	583-14185-00	1			
8	9	127-14186-00	1			
8	10	583-14184-00	1			
8	11	2Y0-14181-00-12	1			
8	12	92901-06100	4			
8	13	92501-06014	4			
8	14	558-14147-00	1			
8	15	2Y0-14115-00	1			
8	16	583-14112-40	1			
8	17	1T1-14116-02	1			
8	18	164-14137-00	1			
8	19	583-14291-00	1			
8	20	98501-04012	2			
8	21	92901-04100	2			
8	22	583-14274-00	1			
8	23	583-14933-00	1			
8	24	583-14558-00	2			
8	25	583-14386-00	1			
8	26	583-14951-00	1			
8	27	583-14216-00	1			
8	28	3H1-14292-00	1			
8	29	2V0-14592-00	1			
8	30	92902-05100	1			
8	31	583-14536-00	1			
8	32	583-14158-00	1			
8	33	98501-04014	2			
8	34	92901-04100	2			
8	35	127-14134-00	1			
8	36	354-14147-00	1			
8	37	525-14123-00	1			
8	38	583-14264-00	1			

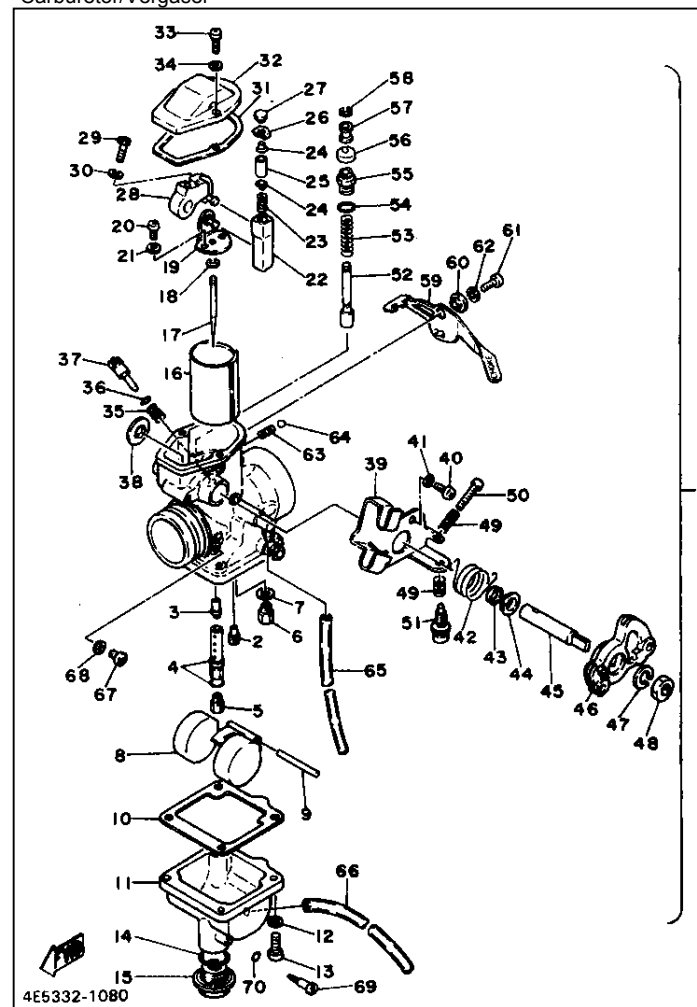

Fig. Pos.	Part No.	Description	Q'ty	Remark/Normteil/Maß	Baugruppe	Figure/Bild
8	39	2J2-14571-00		BRACKET, throttle	1	
8	40	98501-05012		SCREW, pan head	2	
8	41	92901-05100		WASHER, spring	2	
8	42	583-14131-01		SPRING, throttle valve	1	
8	43	583-14239-01		SEAL	1	
8	44	583-14265-00		WASHER	1	
8	45	3H1-14215-00		SHAFT, throttle lever	1	
8	46	583-14573-00		LEVER	1	
8	47	92901-08100		WASHER, spring	1	
8	48	812-14594-00		NUT	1	
8	49	2J2-14133-00		SPRING, throttle stop	2	
8	50	583-14245-01		SCREW, guide	1	
8	51	2J2-14121-00		SCREW, throttle stop	1	
8	52	583-14171-01		PLUNGER, starter	1	
8	53	500-14135-00		SPRING, Plunger	1	
8	54	583-14562-00		O-RING	1	
8	55	583-14174-00		CAP, Plunger	1	
8	56	802-14173-00		COVER, Plunger cap	1	
8	57	583-14918-00		RING	1	
8	58	737-14137-00		CLIP	1	
8	59	583-14175-01		LEVER, starter 1	1	
8	60	583-14594-00		COLLAR	1	
8	61	92501-06012		SCREW, pan head	1	
8	62	92901-06100		WASHER, spring	1	
8	63	583-14589-00		SPRING	1	
8	64	93501-08001		BALL	1	
8	65	1E6-14197-00		PIPE	1	
8	66	432-14197-00		PIPE	1	
8	67	341-14991-00		SCREW	1	
8	68	684-14956-00		WASHER	1	
8	69	2L1-14191-00		PLUG, drain	1	
8	70	214-14147-00		O-RING	1	

Fig. Pos.	Part No.	Description	Q'ty	Remark/Normteil/Maß
9	1	1T1-14611-02	1	PIPE, exhaust 1
9	2	1T1-14628-00	1	PROTECTOR, exhaust pipe
9	3	98906-06010	2	SCREW, bind
9	4	583-14766-00	2	WASHER, protector
9	5	1E6-14766-01	2	WASHER, protector
9	6	90206-06060	2	WASHER, wave
9	7	95621-08615	2	BOLT, stud
9	8	90430-38054	1	GASKET
9	9	90179-08004	2	NUT
9	10	1T1-14714-01	1	GASKET, muffler
9	11	1T1-14788-00	1	BAND, silencer
9	12	1U6-14710-51	1	MUFFLER ASSY 1
9	13	1T1-14718-00	1	PROTECTOR, muffler 1
9	14	98906-06010	3	SCREW, bind
9	15	583-14766-00	3	WASHER, protector
9	16	1E6-14766-01	3	WASHER, protector
9	17	1T2-14728-00	1	PROTECTOR, muffler 2
9	18	98906-06012	3	SCREW, bind
9	19	583-14766-00	3	WASHER, protector
9	20	1E6-14766-01	6	WASHER, protector
9	21	90387-08572	2	COLLAR
9	22	1T1-14747-01	4	DAMPER, muffler
9	23	90209-08162	2	WASHER
9	24	90209-12163	2	WASHER
9	25	91316-08050	1	BOLT
9	26	90110-08018	1	BOLT, hexagon socket head
9	27	1T1-14791-01	1	STAY, muffler
9	28	1T1-14755-01	1	GASKET, silencer
9	29	95601-08100	2	NUT, u
9	30	90202-08103	2	WASHER, plate
9	31	90201-08326	2	WASHER, plate
9	32	92901-08100	3	WASHER, spring
9	33	92901-08600	1	WASHER, plate
9	34	95303-08800	1	NUT, crown

Baugruppe
Exhaust/Auspuff

Figure/Bild

9

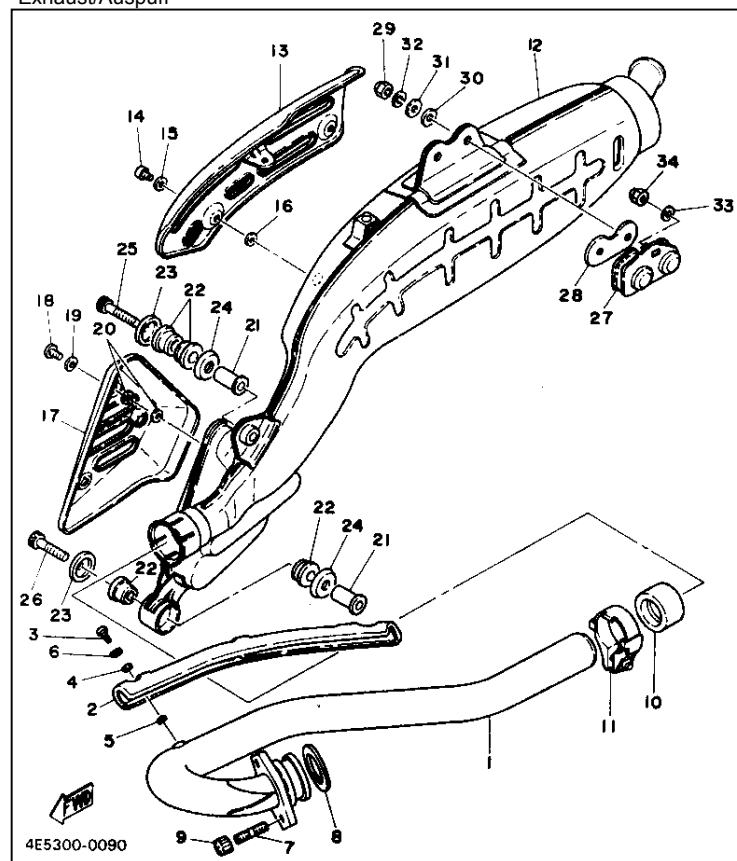

Fig. Pos.	Part No.	Description	Q'ty	Remark/Normteil/Maß	Baugruppe	Figure/Bild
10	1	2Y0-15100-00	1		Crankcase/Kurbelgehäuse	10
10	2	91810-05016	2			
10	3	583-15371-00	1			
10	4	91316-06035	8			
10	5	91316-06045	4			
10	6	91316-06065	1			
10	7	91316-06055	1			
10	8	583-15358-00	1			
10	9	583-15346-00	1			
10	10	583-15347-00	1			
10	11	90460-71017	1			
10	12	90460-22083	2			
10	13	90430-09121	1			
10	14	90465-05084	1			
10	15	363-15381-00	1			
10	16	98701-05012	3			
10	17	90445-07039	1			
10	18	90465-05075	1			
10	19	92501-06012	1			
10	20	583-15316-00	2			
10	21	583-15317-01	1			
10	22	93210-12095	2			
10	23	583-15383-00	1			
10	24	92701-06015	2			
10	25	583-15426-00	1			
10	26	583-15466-00	1			
10	27	92501-06018	4			

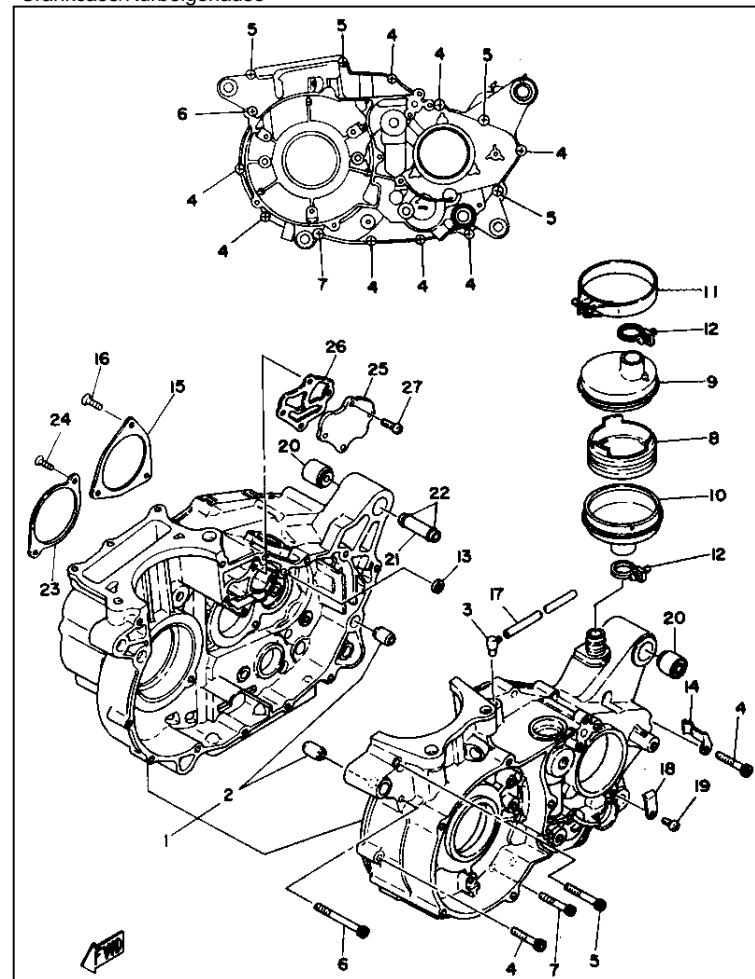

Fig. Pos.	Part No.	Description	Q'ty	Remark/Normteil/Maß	Baugruppe	Figure/Bild
11	1	583-15411-00	1	COVER, crankcase 1	Crankcase Cover/Kurbelgehäuse-Deckel	11
11	2	683-15451-00	1	GASKET, crankcase cover		
11	3	91316-06025	4	BOLT		
11	4	91316-06035	1	BOLT		
11	5	1E6-15420-11	1	CRANKCASE COVER ASSY (L.H)		
11	6	91316-06035	3	BOLT		
11	7	583-15431-02-98	1	COVER, crankcase 3		
11	8	93101-14089	1	OIL SEAL		
11	9	93420-25002	1	CIRCLIP		
11	10	93102-15147	1	OIL SEAL		
11	11	583-15462-00	1	GASKET, crankcase cover 3		
11	12	583-15425-00	1	COVER, generator 2		
11	13	93210-35173	1	O-RING		
11	14	91316-06030	8	BOLT		
11	15	91316-06040	2	BOLT		
11	16	91830-22016	2	PIN, dowel		
11	17	583-15417-00	1	COVER, cap		
11	18	583-15457-00	1	GASKET		
11	19	91316-06025	2	BOLT		
11	20	90430-10027	1	GASKET		
11	21	90340-10003	1	PLUG, straight screw		
11	22	90465-08076	1	CLAMP		

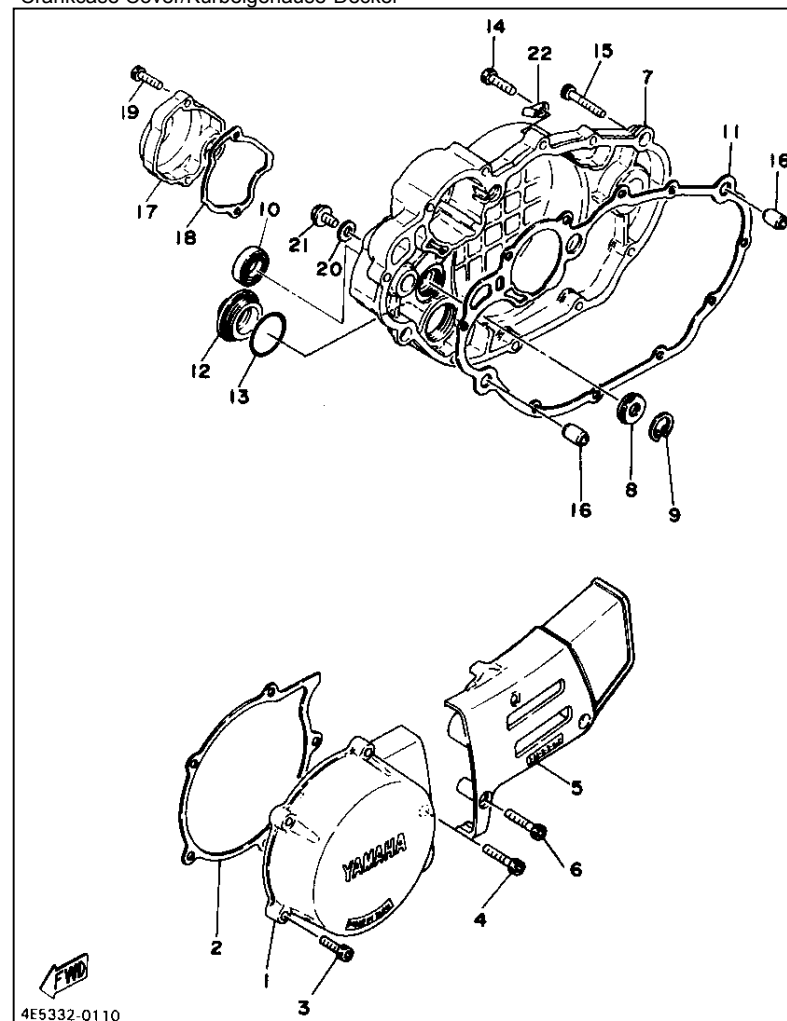

Fig. Pos.	Part No.	Description	Q'ty	Remark/Normteil/Maß	Baugruppe	Figure/Bild
12	1	2H0-81300-50	1		Fly Wheel Magneto/Lichtmaschine	12
12	2	2H0-81350-50	1			
12	3	583-81309-50	1			
12	4	583-81311-50	1			
12	5	583-81345-50	2			
12	6	2H0-81313-50	1			
12	7	1E6-81346-50	2			
12	8	2H0-81315-50	1			
12	9	1E6-81328-50	1			
12	10	583-81346-50	1			
12	11	92502-06016	3			

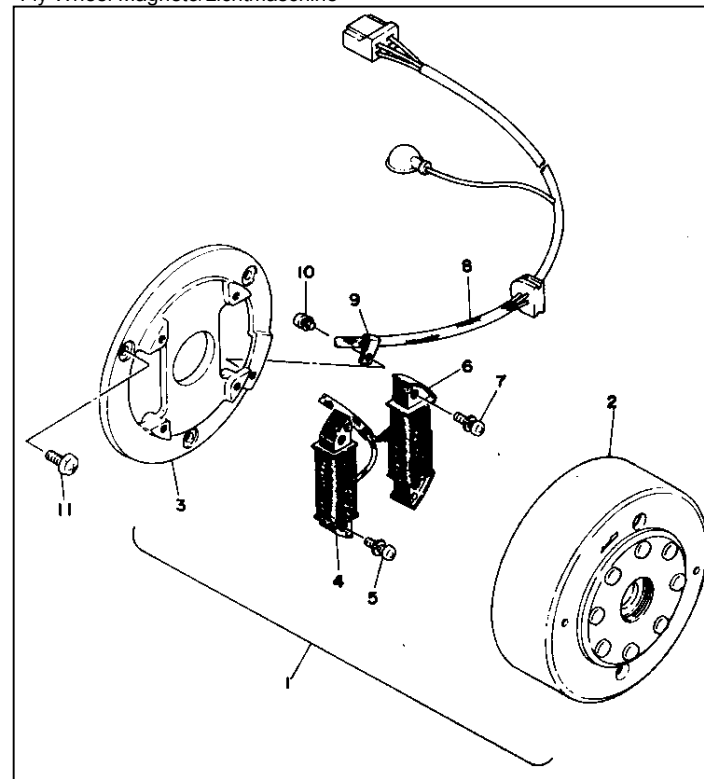

Fig. Pos.	Part No.	Description	Q'ty	Remark/Normteil/Maß	Baugruppe	Figure/Bild
13	1	583-81620-50	1	BREAKER PLATE ASSY	Breaker & Governor/Unterbrecher & Zündkraftversteller	13
13	2	583-81621-50	1	CONTACT BREAKER ASSY		
13	3	583-81645-50	3	SCREW		
13	4	583-81615-50	1	WIRE, lead		
13	5	583-81631-50	1	LUBRICATOR		
13	6	583-81625-50	1	CONDENCER		
13	7	97801-06014	2	SCREW, pan head		
13	8	92901-06200	2	WASHER, plain		
13	9	583-81653-50	1	GOVERNOR ASSY		
13	10	97301-06016	1	BOLT		
13	11	90201-06060	1	WASHER, plate		

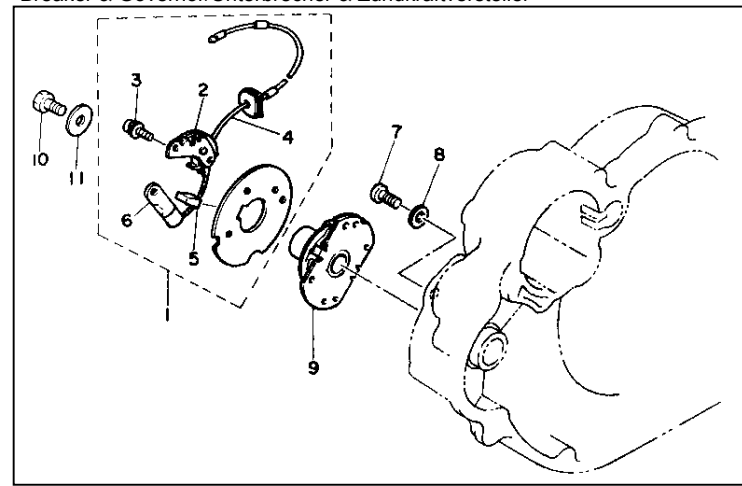

Fig. Pos.	Part No.	Description	Q'ty	Remark/Normteil/Maß
14	1	1T1-15620-00	1	KICK CRANK ASSY
14	2	583-15621-00	1	BOSS, kick crank
14	3	93507-32009	1	BALL
14	4	90501-12081	1	SPRING, compression
14	5	90201-15234	1	WASHER, plate
14	6	93430-10016	1	CIRCLIP
14	7	1T1-15618-00	1	COVER, kick lever
14	8	97321-08030	1	BOLT
14	9	583-15661-00	1	AXLE, kick
14	10	583-15671-00	1	WHEEL, ratchet
14	11	90501-23143	1	SPRING, compression
14	12	363-15676-00	1	COVER, spring
14	13	93410-19015	1	CIRCLIP
14	14	90201-25287	2	WASHER, plate
14	15	93440-25020	1	CIRCLIP
14	16	583-15641-00	1	GEAR, kick (29T)
14	17	93440-25019	1	CIRCLIP
14	18	583-15676-00	1	COVER, spring
14	19	90508-32280	1	SPRING, torsion
14	20	90560-25154	1	SPACER
14	21	93410-25010	1	CIRCLIP
14	22	90201-25290	1	WASHER, plate
14	23	90201-20278	1	WASHER, plate
14	24	583-15674-00		GUIDE, ratchet wheel
14	25	363-15686-00		WASHER, lock
14	26	434-15668-00	1	STOPPER
14	27	97321-06016	3	BOLT
14	28	583-15651-00	1	GEAR, sprocket idle (27T)
14	29	90201-17255	1	WASHER, plate
14	30	93416-17008	1	CIRCLIP
14	31	583-15631-00	1	GEAR, kick pinion (19T)
14	32	93102-25064	1	OILSEAL

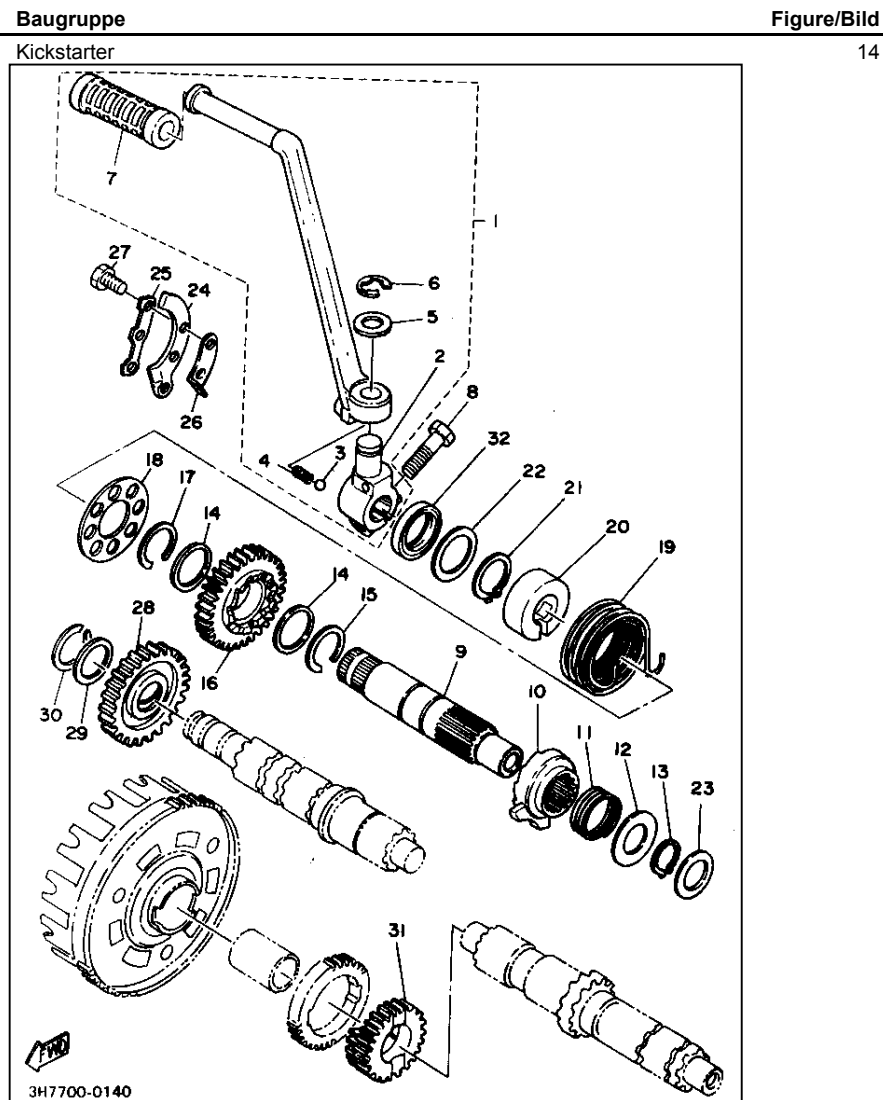

Fig. Pos.	Part No.	Description	Q'ty	Remark/Normteil/Maß
15	1	583-16150-00	1	PRIMARY DRIVEN GEAR COMP.(77T)
15	2	170-16164-00	1	PLATE, thrust 2
15	3	583-16371-00	1	BOSS, clutch
15	4	583-16321-00	8	PLATE, friction
15	5	360-16325-00	7	PLATE, clutch 2
15	6	498-16351-00	1	PLATE, pressure 1
15	7	90501-23391	6	SPRING, compression
15	8	90159-06010	6	SCREW, with washer
15	9	90560-25153	1	SPACER
15	10	583-16111-00	1	GEAR, primary drive (30T)
15	11	90282-07021	1	KEY, straight
15	12	90208-16019	1	WASHER, conical spring
15	13	90170-16182	1	NUT
15	14	363-16154-00	1	PLATE, thrust 1
15	15	214-16119-00	1	SPRING, belleville
15	16	99170-18086	1	NUT
15	17	174-16356-00	1	ROD, Push 1
15	18	583-16357-01	1	ROD, Push 2
15	19	583-16382-00	1	AXLE, Push lever
15	20	214-16389-00	1	JOINT
15	21	90240-06005	1	PIN, clevis
15	22	91401-10010	1	PIN, cotter
15	23	90508-12279	1	SPRING, torsion
15	24	93315-11720	2	BEARING, cylindrical
15	25	93102-17148	1	OIL SEAL
15	26	90201-17327	1	WASHER, plate
15	27	364-16343-00	1	SCREW, adjusting
15	28	583-16344-00	1	NUT, adjusting
15	29	90201-12172	1	WASHER, plate

Baugruppe
Clutch/Kupplung

Figure/Bild

15

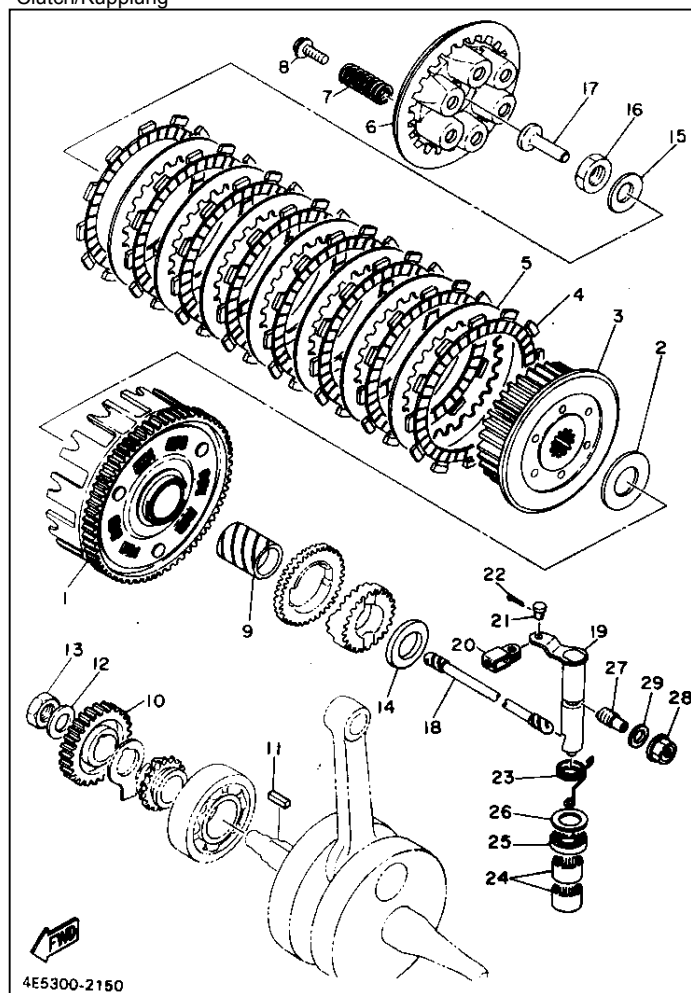

Fig. Pos.	Part No.	Description	Q'ty	Remark/Normteil/Maß
16	1	583-17411-01	1	AXLE, main (14T)
16	2	168-17428-01-05	1	SHIM 2 (0.5T)
16	3	93306-20546	1	BEARING
16	4	90201-252A4	1	WASHER, plate
16	5	583-17121-00	1	GEAR, 2nd pinion (18T)
16	6	583-17131-02	1	GEAR, 3rd pinion (21T)
16	7	583-17141-00	1	GEAR, 4th pinion (24T)
16	8	583-17151-01	1	GEAR, 5th pinion (27T)
16	9	90201-25287	3	WASHER, plate
16	10	93440-25020	3	CIRCLIP
16	11	90201-20266	1	WASHER, plate
16	12	93311-42012	1	BEARING, cylindrical
16	13	2H0-17421-01	1	AXLE, drive
16	14	90338-09066	1	PLUG
16	15	583-17211-00	1	GEAR, 1st wheel (33T)
16	16	583-17221-00	1	GEAR, 2nd wheel (28T)
16	17	583-17231-01	1	GEAR, 3rd wheel (25T)
16	18	583-17241-00	1	GEAR, 4th wheel (22T)
16	19	583-17251-01	1	GEAR, 5th wheel (21T)
16	20	90201-25287	3	WASHER, plate
16	21	93440-25020	3	CIRCLIP
16	22	90201-20278	1	WASHER, plate
16	23	93410-20038	2	CIRCLIP
16	24	90201-20266	1	WASHER, plate
16	26	93313-32008	1	BEARING, cylindrical
16	26	93306-30517	1	BEARING (B6305)
16	27	93102-35180	1	OIL SEAL
16	28	90387-25507	1	COLLAR
16	29	93210-22298	1	O-RING
16	30	214-17461-60	1	SPROCKET, drive (16T)
16	31	90215-21022	1	WASHER, lock
16	32	90179-18020	1	NUT

Baugruppe
Transmission/Getriebe

Figure/Bild

16

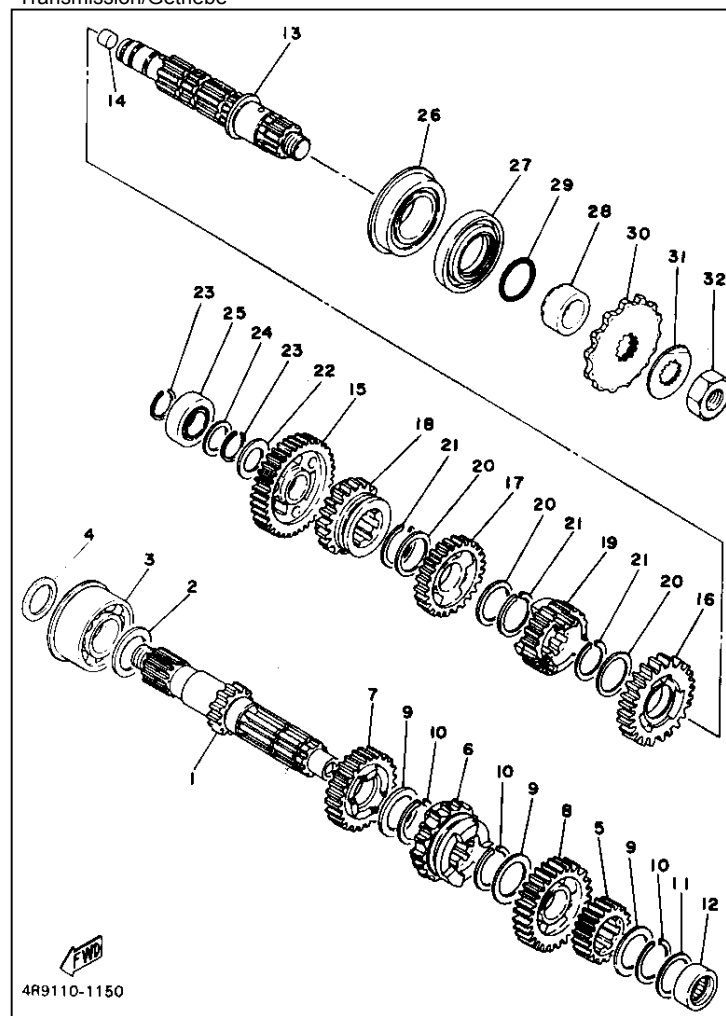

Fig. Pos.	Part No.	Description	Q'ty	Remark/Normteil/Maß	Baugruppe	Figure/Bild
17 1	2J2-18540-00	SHIFT CAM ASSY	1		Shift Cam & Fork/Schaltwalze & -gabel	17
17 2	93604-18100	PIN, dowel	6			
17 3	434-18561-00	PLATE, side 1	1			
17 4	98701-05012	SCREW, flat head	1			
17 6	2J2-18141-00	PLATE, stopper	1			
17 6	93410-30012	CIRCLIP	1			
17 7	93604-08071	PIN, dowel	1			
17 8	90201-32673	WASHER, Piste	1			
17 9	93315-23208	BEARING, cylindrical	1			
17 10	1J7-18547-00	STOPPER, cam	1			
17 11	90501-10062	SPRING, compression	1			
17 12	90149-14031	SCREW	1			
17 13	137-15353-00	GASKET, drain	1			
17 14	364-18511-00	FORK, shift 1	2			
17 15	363-18511-00	FORK, shift 1	1			
17 16	90250-08017	PIN, straight	3			
17 17	363-18531-00	BAR, shift fork guide 1	1			
17 18	363-18535-00	BAR, shift fork guide 2	1			
17 19	93430-08006	CIRCLIP	5			
17 20	434-18122-00	LEVER, shift 2	1			
17 21	90508-08334	SPRING, torsion	1			
17 22	498-18151-03	LEVER, shift 3	1			
17 23	93430-07012	CIRCLIP	1			

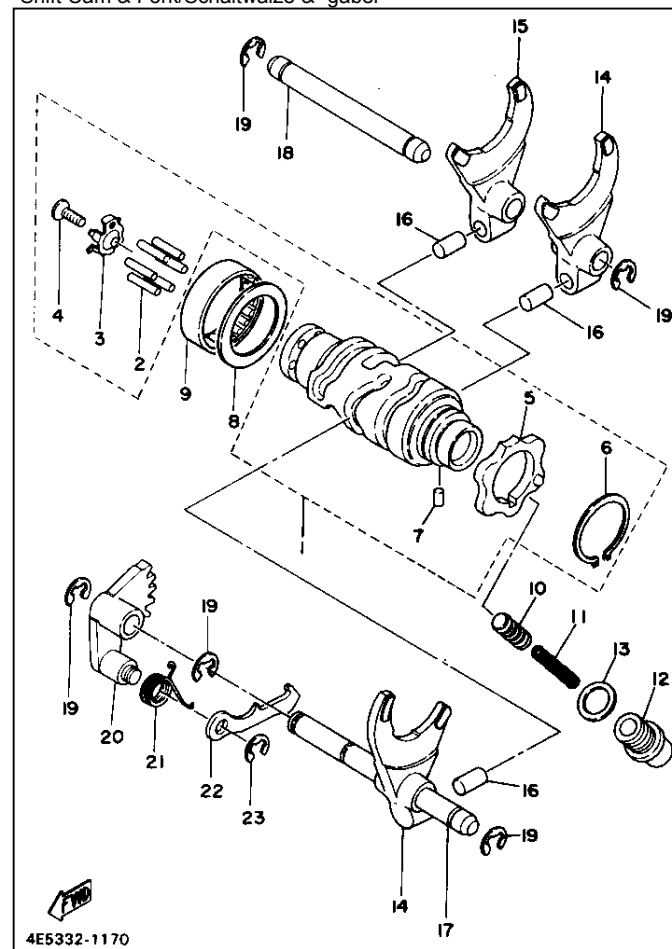

Fig. Pos.	Part No.	Description	Q'ty	Remark/Normteil/Maß	Baugruppe	Figure/Bild
18	1	2J2-18103-00	1		Shift Shaft & Pedal/Schaltwelle & -hebel	18
18	2	90149-06017	1			
18	3	95301-06600	1			
18	4	90508-32052	1			
18	5	90215-06016	1			
18	6	92901-08100	1			
18	7	278-18127-00	1			
18	8	90215-08115	1			
18	9	93109-14010	1			
18	10	90201-14220	1			
18	11	93430-12009	1			
18	12	583-18131-00	1			
18	13	583-18111-01-93	1			
18	14	132-18113-01	1			
18	15	97321-06020	1			

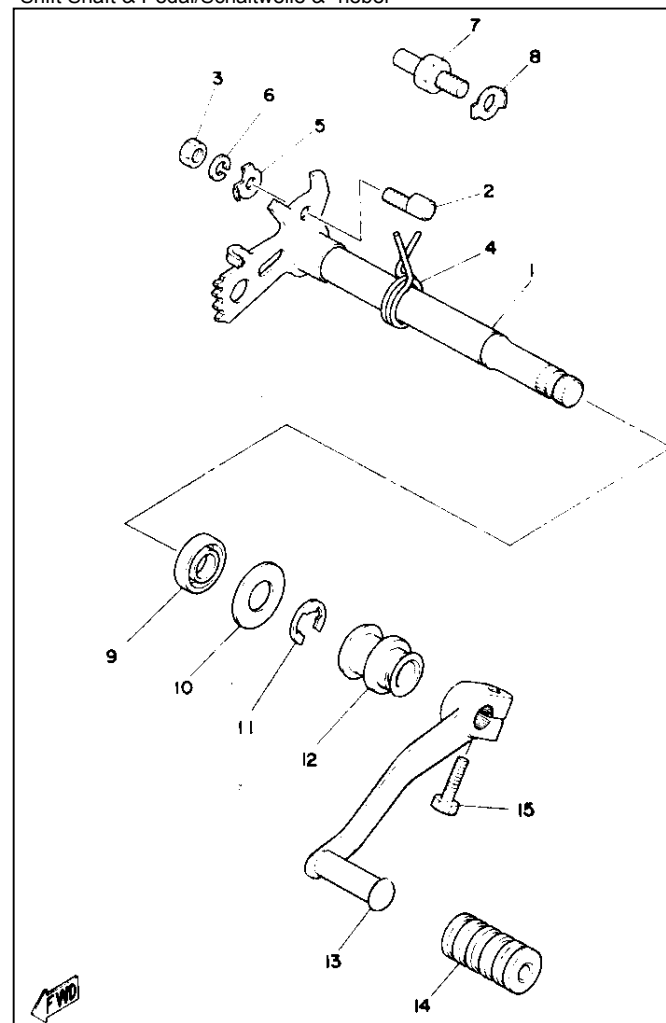

Fig.	Pos.	Part No.	Description	Q'ty	Remark/Normteil/Maß	Baugruppe	Figure/Bild
19	1	4E5-21110-00-33	FRAME COMP	1	YAMAHA black	Frame/Rahmen	19
19	2	90105-10039	BOLT, washer based	1			
19	3	90105-10063	BOLT, washer based	1			
19	4	90185-10035	NUT, self-locking	4			
19	5	90106-08064	BOLT, washer based	1			
19	6	90106-10051	BOLT, washer based	2			
19	7	90185-08089	NUT, self-locking	1			
19	8	90208-08011	WASHER, conical spring	1			
19	9	90201-10126	WASHER, plate	1			
19	10	583-21316-00	STAY, engine mount	1			
19	11	97321-08025	BOLT	2			
19	12	92901-08100	WASHER, spring	2			
19	13	92901-08600	WASHER, plate	2			
19	14	1T1-21317-00	STAY, engine mount rear	1			
19	15	97321-08025	BOLT	2			
19	16	92901-08100	WASHER, spring	2			
19	17	92901-08600	WASHER, plate	2			
19	18	583-21315-00	STAY, engine 2	2			
19	19	90105-08066	BOLT, washer based	4			
19	20	2H1-21471-00	PROTECTOR, engine	1			
19	21	97301-06014	BOLT	5			
19	22	92901-06100	WASHER, spring	6			
19	23	90201-06657	WASHER, plate	5			
19	24	1E6-21308-00	HELMET HANGER ASSY	1			
19	25	92701-06018	SCREW, flat head	1			
19	26	1T2-21441-00	BRACKET, stop switch	1			
19	27	583-21771-00	BODY, cap	1			
19	28	90430-27124	GASKET	1			
19	29	90445-11289	HOSE	1			
19	30	90467-10008	CLIP	2			
19	31	583-21755-00	CLAMP	1			
19	32	97701-50110	SCREW, Panhead tapping	1			
19	33	583-21756-00	NET, filter	1			
19	34	90430-22123	GASKET	1			
19	35	95801-08012	BOLT, flange	1			
19	36	90430-08119	GASKET	1			
19	37		STEERING LOCK ASSY	1	LM		
19	38	134-23484-10	CAP, handle lock	1			
19	39	90269-04003	RIVET	1			
19	40	90208-04029	WASHER, conical spring	1			

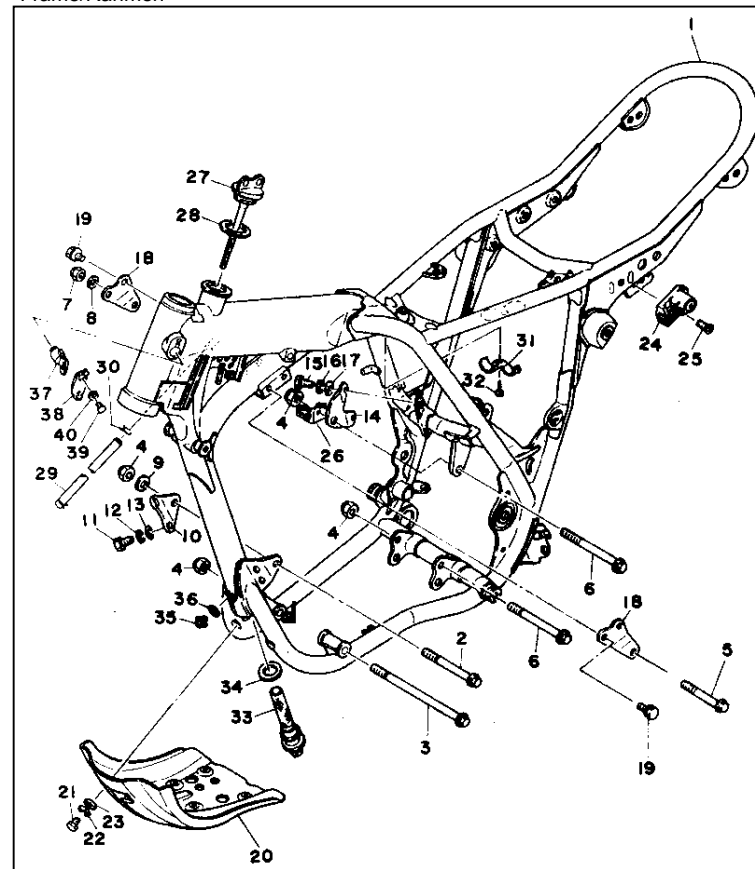

Fig. Pos.	Part No.	Description	Q'ty	Remark/Normteil/Maß
20	1	3H6-21511-00	1	clean white
20	2	90480-14198	4	
20	3	90387-06388	4	
20	4	90201-06067	4	
20	5	97301-06030	4	
20	6	92901-06100	4	
20	7	1U6-21610-00-36	1	clean white
20	8	1E6-21638-00	4	
20	9	90387-07391	2	
20	10	97321-06025	2	
20	11	92901-06100	2	
20	12	97301-08030	1	
20	13	97321-08045	1	
20	14	90170-08216	1	
20	15	90201-08114	2	
20	16	1E6-21639-00	2	
20	17	90387-08258	2	
20	18	92901-08100	2	
20	19	95303-08800	2	
20	20	92901-08200	1	
20	21	90201-08326	1	
20	22	1T1-21620-00	1	
20	23	583-21746-00	1	
20	24	90201-06067	3	
20	25	97321-06014	3	
20	26	92901-36100	3	
20	27	90464-08020	1	

Baugruppe Front Fender & Rear Fender/Kotflügel Figure/Bild 20

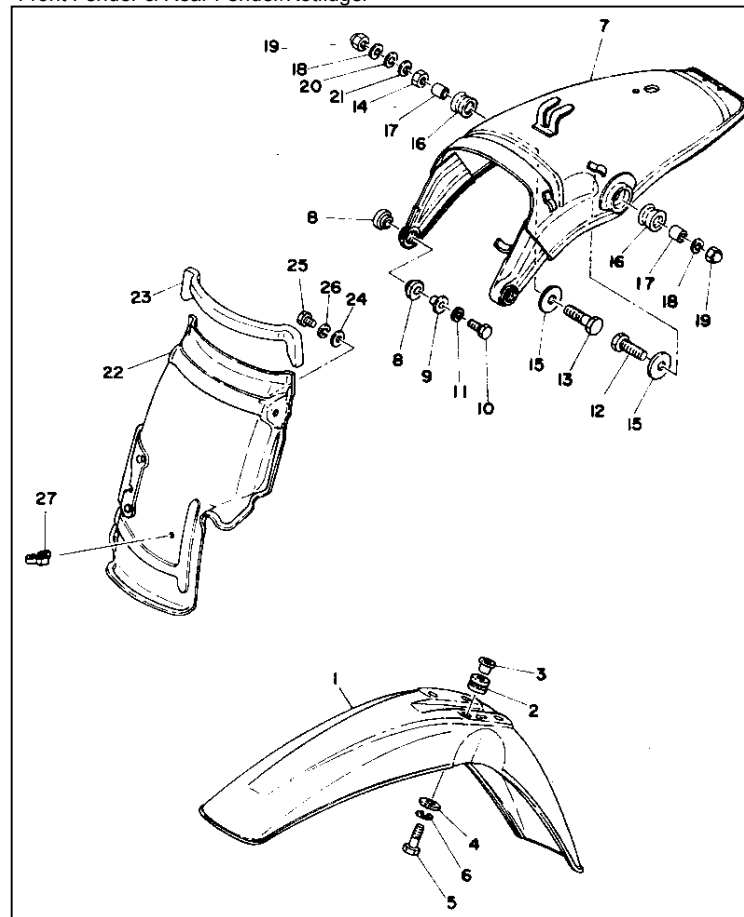

Fig. Pos.	Part No.	Description	Q'ty	Remark/Normteil/Maß
21	1	3H7-21711-00-33	COVER, side 1	1 YAMAHA black
21	2	1E6-21708-00	SIDE COVER LOCK ASSY	1
21	3	90170-22187	NUT	1
21	4	90480-24186	GROMMET	1
21	5	4E5-21786-00	EMBLEM 6	1
21	6	3H7-21721-00-33	COVER, side 2	1 YAMAHA black
21	7	583-21714-00	KNOB, side cover 1	1
21	8	91609-26018	PIN, spring	1
21	9	90201-06063	WASHER, plate	2
21	10	583-21747-00	DAMPER	1
21	11	4E5-21787-00	EMBLEM 7	1
21	12	1T2-21171-00	BOX, tool	1
21	13	683-21714-00	KNOB, side cover 1	1
21	14	91609-25018	PIN, spring	1
21	15	90201-06063	WASHER, plate	1
21	16	583-21747-00	DAMPER	1
21	17	92506-06014	SCREW, pan head	1
21	18	92906-06100	WASHER, spring	1
21	19	92506-06045	SCREW, pan head	1
21	20	95301-06600	NUT	1
21	21	90201-06380	WASHER, plate	3
21	22	92901-06100	WASHER, spring	1
21	23	1U6-21240-00	BOX COMP.	1
21	24	1E6-21245-00	BOX	1
21	25	1E6-21399-00	CAP, battery box	1
21	26	91701-05055	PIN, clevis	1
21	27	90468-10050	CLIP	1
21	28	371-82121-00	PAD, battery	4
21	29	90480-01176	GROMMET	1
21	30	97301-06025	BOLT	2
21	31	92901-06100	WASHER, spring	2
21	32	90480-14102	GROMMET	2
21	33	90387-07391	COLLAR	2
21	34	90445-11418	HOSE	2
21	35	1E6-28100-00	TOOL KIT	1

Baugruppe Side Cover & Tool/Seitendeckel & Werkzeug Figure/Bild 21

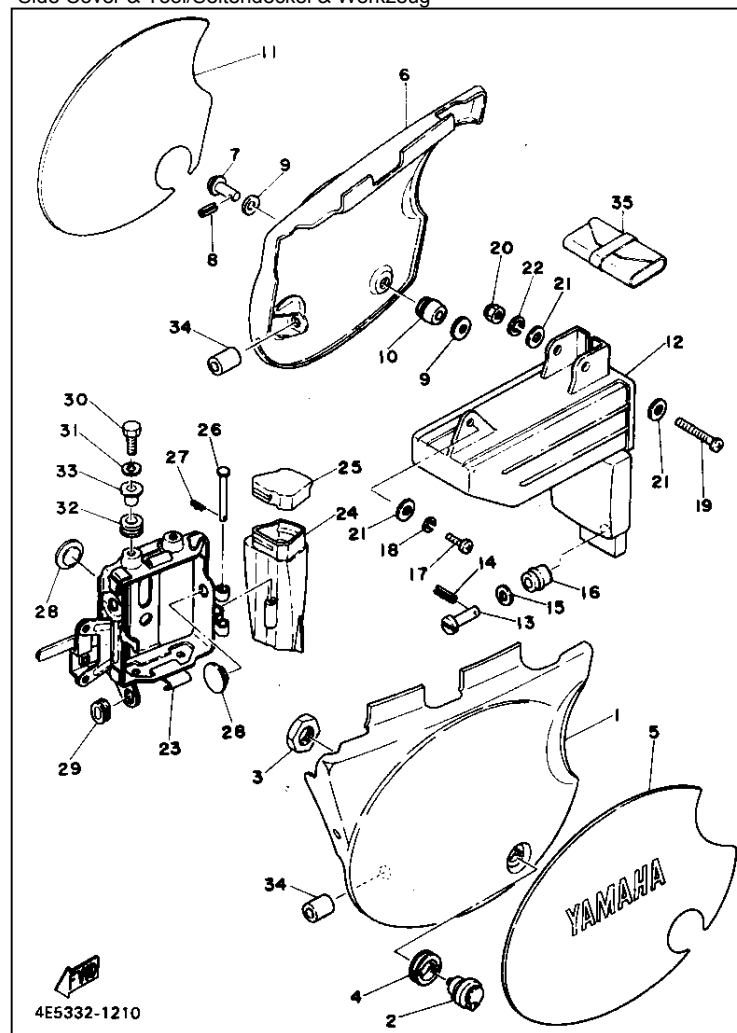

Fig. Pos.	Part No.	Description	Q'ty	Remark/Normteil/Maß
22	1	3H7-22110-00-33	1	YAMAHA black
22	2	93342-22205	2	
22	3	93317-22208	2	
22	4	483-22124-00	1	
22	5	648-45533-00-03	1	UR
22	6	2K8-22129-00	2	
22	7	431-22151-03	1	
22	8	93108-35004	2	
22	9	583-22141-01		
22	10	95601-18100		
22	11	90208-16019	2	
22	12	1U6-22318-00-33	1	YAMAHA black
22	13	97301-08016	1	
22	14	92901-08100	1	
22	15	97301-06016	2	
22	16	92901-06100	2	
22	17	1U6-22311-00-33	1	YAMAHA black
22	18	98501-05016	2	
22	19	92901-05100	2	
22	20	98501-05010	2	
22	21	92901-06100	2	
22	22	90560-05001	2	
22	23	90387-06009	2	
22	24	90201-06407	4	
22	25	90480-12188	2	
22	26	90480-08216	2	
22	27	93700-06004	1	
22	28	2Y0-22179-00	1	
22	29	2N0-22178-00	1	
22	30	93104-14044	2	
22	31	98501-05040	2	
22	32	92901-05100	2	
22	33	90508-35387	1	
22	34	90109-10533	1	
22	35	90201-14577	1	
22	36	1E6-27430-00	2	
22	37	465-27431-00	1	
22	38	120-27432-02	1	
22	39	120-27433-00	1	
22	40	90201-20279	1	

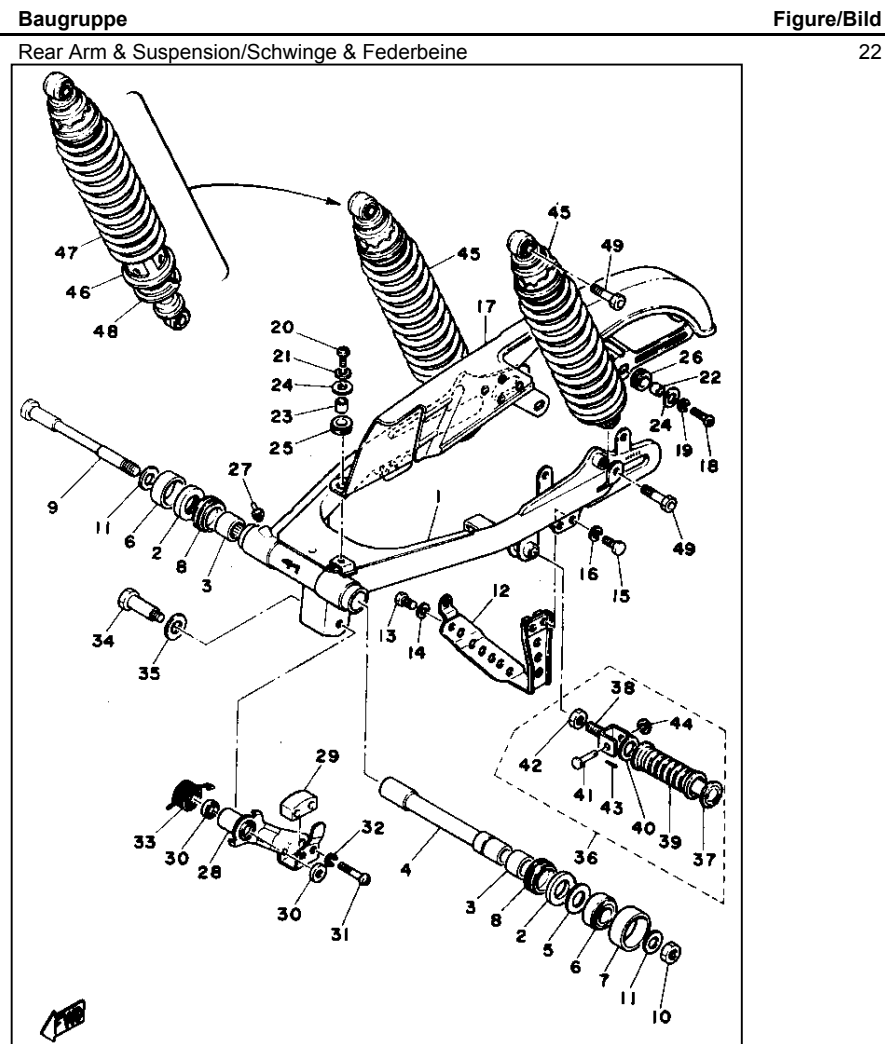

Fig. Pos.	Part No.	Description	Q'ty	Remark/Normteil/Maß	Baugruppe	Figure/Bild
22 41	90240-06052	PIN, clevis	1			
22 42	95301-12700	NUT	1			
22 43	91401-20015	PIN, cotter	1			
22 44	90201-06055	WASHER, plate	1			
22 45	3H7-22210-00	SHOCK ABSORBER ASSY, rear	2			
22 46	1T1-22211-00	GUIDE, spring	1			
22 47	1T1-22212-00	SPRING	1			
22 48	583-22214-00	SEAT, spring	1			
22 49	90109-10420	BOLT	4			

Fig. Pos.	Part No.	Description	Q'ty	Remark/Normteil/Maß
23	1	156-23411-00	1	RACE, ball 1
23	2	164-23462-00	1	SEAL, steering
23	3	3H7-23435-00-98	1	CROWN, handle
23	4	1E6-23445-00	2	DAMPER
23	5	1E6-23441-00-98	2	HOLDER, handle upper
23	6	1E6-23442-00	2	HOLDER, handle lower
23	7	90105-08091	4	BOLT, washer based
23	8	1T2-23389-00	1	GUIDE, cable
23	9	90201-12195	2	WASHER, plate
23	10	90201-10322	2	WASHER, plate
23	11	1E6-23434-00	4	HOLDER, damper
23	12	92901-10100	2	WASHER, spring
23	13	95301-10700	2	NUT
23	14	90468-12006	2	CLIP
23	15	95821-08040	4	BOLT, flange
23	16	95821-08055	1	BOLT, flange
23	17	95701-08100	1	NUT, flange
23	18	90105-14102	1	BOLT, washer based
23	19	583-23469-00	1	CAP, bolt
23	20	156-23412-00	1	RACE, ball 2
23	21	93501-04011	19	BALL
23	22	122-23411-00	1	RACE, ball 1
23	23	122-23412-00	1	RACE, ball 2
23	24	93503-16010	22	BALL
23	25	2Y0-23416-00	1	COVER, ball race 2
23	26	90179-25033	1	NUT
23	27	584-82519-00	1	WIRE, earth lead

Baugruppe
Steering/Lenkkopf & Gabelbrücken

Figure/Bild

23

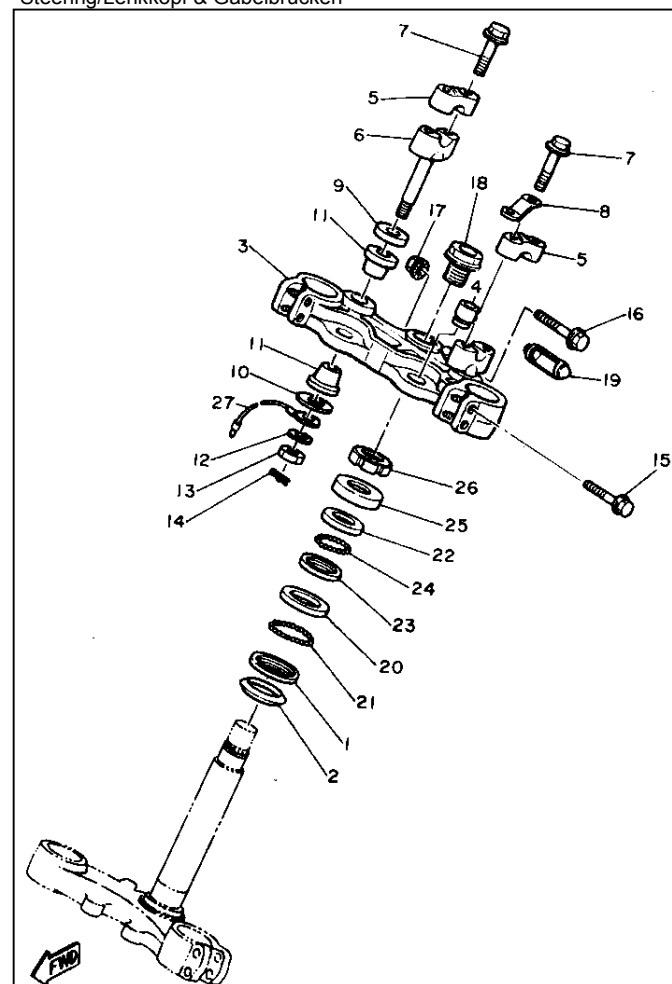

Fig. Pos.	Part No.	Description	Q'ty	Remark/Normteil/Maß	Baugruppe
24	1	4E5-23101-30	1		Front Fork/Telegabel
24	2	2W6-23126-00	1		
24	3	2W6-23136-00	1		
24	4	197-23145-00	2		
24	5	509-23146-L0	2		
24	6	1W1-23156-L0	2		
24	7	1W1-23153-L0	2		
24	8	1G8-23144-L1	2		
24	9	1W1-23148-L0	2		
24	10	1W1-23168-L0	2		
24	11	2Y0-23173-00	2		
24	12	2Y0-23170-00	2		
24	13	3H7-23124-00	2		
24	14	1W1-23318-L0	1		
24	15	509-23489-L0	1		
24	16	2N6-23191-00	2		
24	17	341-92090-60	2		
24	18	509-23194-L0	2		
24	19	3H7-23141-00	2		
24	20	583-23142-00	2		
24	21	1W6-23118-10	2		
24	22	240-23114-00	2		
24	23	1U6-231111-M1	2		
24	24	1U6-23168-M0	2		
24	25	4E5-23340-30-33	1	YAMAHA black	
24	26	90109-08397	3		
24	27	90101-08340	1		
24	28	90201-08544	5		
24	29	1E6-23317-10	1		
24	30	90462-08024	1		
24	31	92901-08100	4		
24	32	96311-08600	4		
24	33	509-23158-L0	2		
24	34	278-23181-50	2		
24	35	122-23129-00	2		
24	36	122-23119-01	2		
24	37	1T2-23318-00	1		
24	38	1E6-23319-00	1		
24	39	559-21541-00	1		
24	40	97301-06020	1		

Front Fork/Telegabel

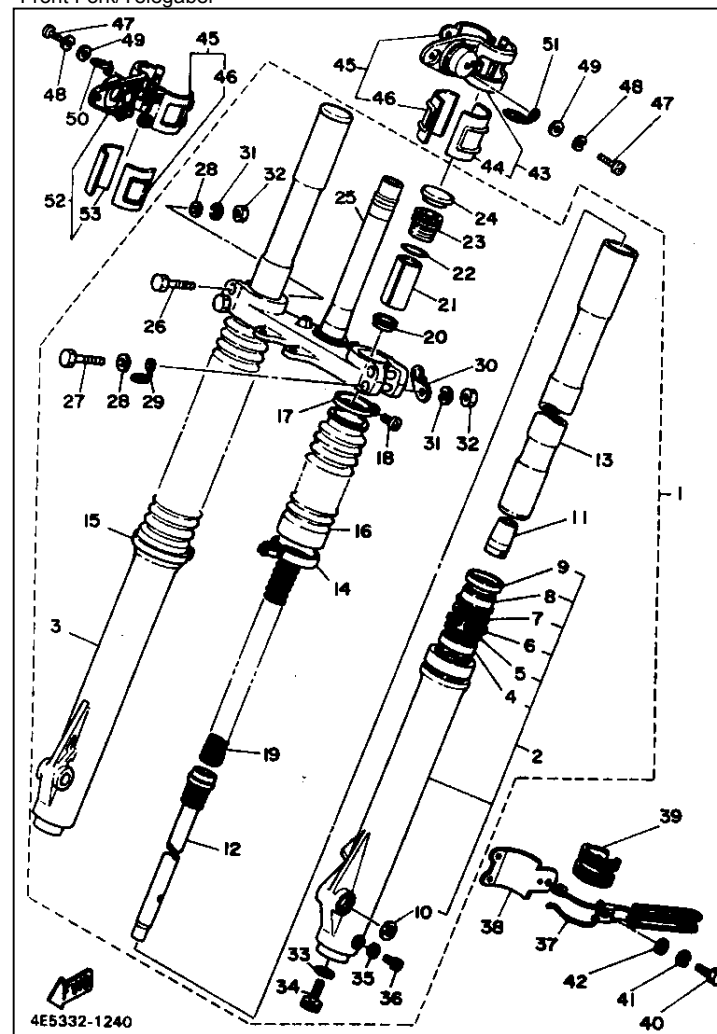

Fig. Pos.	Part No.	Description	Q'ty	Remark/Normteil/Maß	Baugruppe	Figure/Bild
24	41	92901-06100	1	WASHER, spring		
24	42	92901-06600	1	WASHER, plate		
24	43	4E5-23122-00-33	1	COVER, outer 1	YAMAHA black	
24	44	1N5-23138-00	1	GASKET, upper cover 2		
24	45	3H7-23131-00-33	2	COVER, upper 2	YAMAHA black	
24	46	1N5-23137-00	1	GASKET, upper cover 1		
24	47	92501-06020	4	SCREW, pan head		
24	48	92901-06100	4	WASHER, spring		
24	49	92901-06600	4	WASHER, plate		
24	50	1E6-23389-00	1	GUIDE, cable		
24	51	90468-23097	1	CLIP		
24	52	4E5-23132-00-33	1	COVER, outer 2	YAMAHA black	
24	53	1N5-23138-00	1	GASKET, upper cover 2		

Fig. Pos.	Part No.	Description	Q'ty	Remark/Normteil/Maß
25	1	3H7-24110-00-04	1	new YAMAHA black
25	2	4E5-24240-10	1	
25	3	4E5-24161-10	2	
25	4	498-24500-01	1	
25	5	498-24523-00	1	
25	6	498-24528-00	1	
25	7	498-24524-01	1	
25	8	90206-18025	1	
25	9	498-24526-00	1	
25	10	214-24535-00	2	
25	11	498-24522-00	1	
25	12	498-24521-00	1	
25	13	214-24512-00	1	
25	14	90149-06008	2	
25	15	90202-06010	2	
25	16	90445-11288	1	
25	17	90467-10008	2	
25	18	2A6-24611-00	1	
25	19	1W1-24612-00	1	
25	20	90445-09119	1	
25	21	90480-22177	2	
25	22	90387-09506	2	
25	23	90201-06073	2	
25	24	97321-06030	2	
25	25	92901-06100	2	
25	26	90480-22054	1	
25	27	90209-08097	1	
25	28	97301-08016	1	
25	29	92901-08100	1	
25	30	583-24181-00	2	
25	31	98501-05012	2	
25	32	92901-05100	2	
25	33	583-24182-00	2	

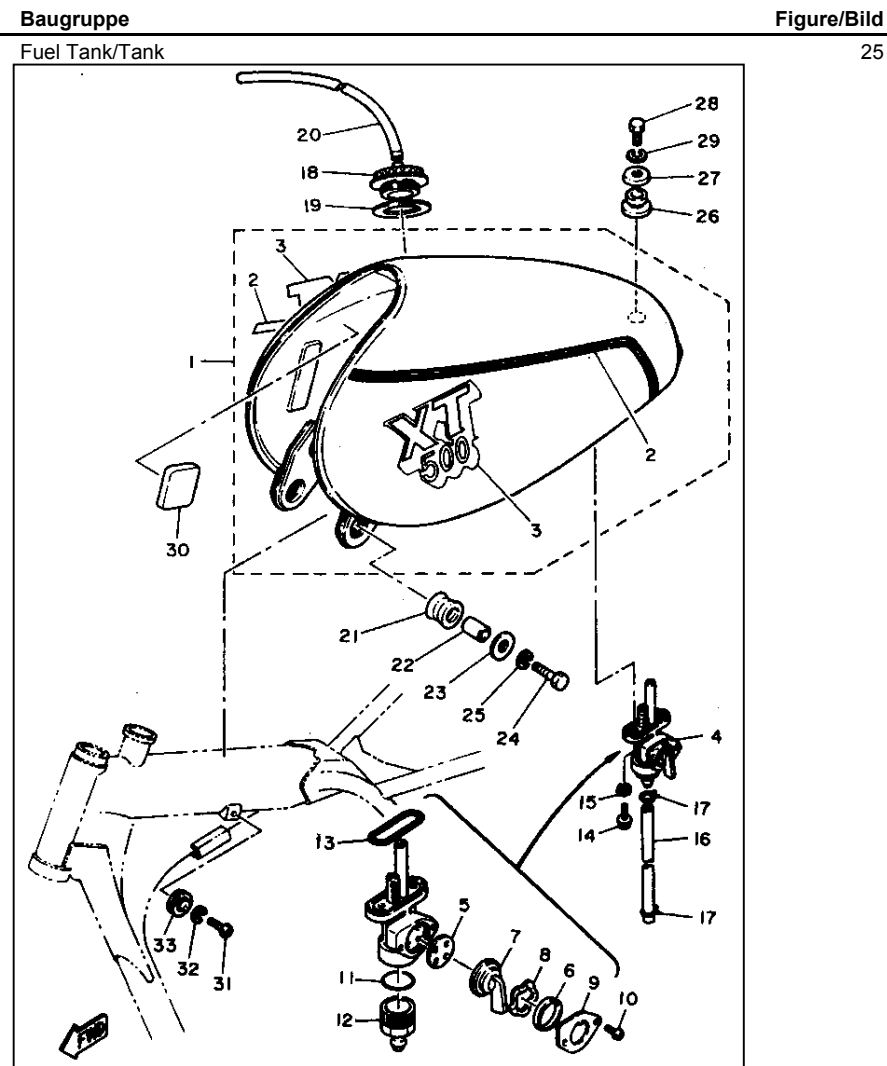

Fig. Pos.	Part No.	Description	Q'ty	Remark/Normteil/Maß	Baugruppe	Figure/Bild
26	1	4E5-W2472-00	1		Seat/Sitzbank	26
26	2	4E5-24731	1			
26	3	2Y0-24748-00	1			
26	4	1T1-24738-00	2			
26	5	583-24724-00	2			
26	6	90101-06304	6			
26	7	97321-08016	2			
26	8	92901-08100	2			
26	9	92901-08600	2			
26	10	3H7-24720-00	1			
26	11	90109-08444	2			

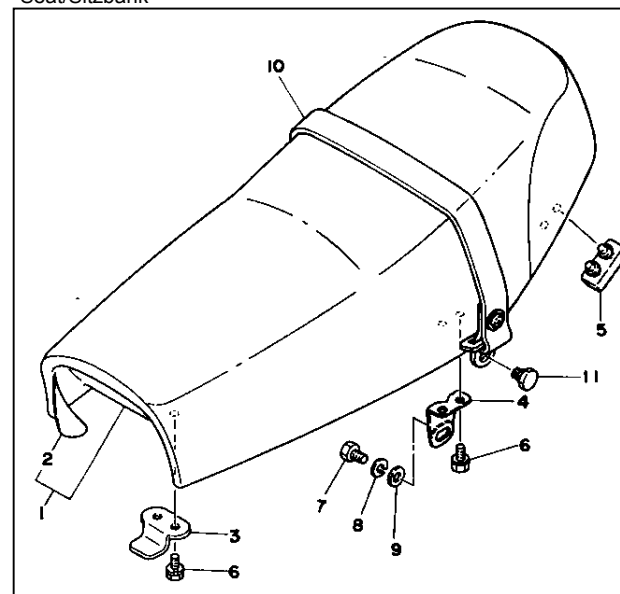

Fig. Pos.	Part No.	Description	Q'ty	Remark/Normteil/Maß
27	1	1E6-25111-00-98	1	low gloss black
27	2	183-25315-00	1	
27	3	214-25117-00	1	
27	4	93306-20203	1	
27	5	93306-20205	1	
27	6	93102-20009	1	
27	7	2N6-25016-10-98	1	low gloss black
27	8	90480-10068	1	
27	9	431-25330-02	2	
27	10	90507-20002	2	
27	11	308-25135-00	1	
27	12	109-26136-00	1	
27	13	308-25138-00	1	
27	14	93104-07003	1	
27	15	93105-50010	1	
27	16	90201-22283	2	
27	17	90201-07076	1	
27	18	93410-22014	1	
27	19	214-25149-01	1	
27	20	1E6-25151-00	1	
27	21	148-25353-00	1	
27	22	2N6-25155-00	1	
27	23	90101-06278	1	
27	24	95601-06100	1	
27	25	94418-21201	1	
27	26	1E6-25104-01	1	
27	27	94132-21254	1	
27	28	94232-21124	1	
27	29	94330-21084	1	bridgestone
27	30	1T2-25394-00	1	
27	31	156-25398-00	1	UN
27	32	1W1-25181-01	1	
27	33	322-25118-00	1	
27	34	90387-15720	1	
27	36	90171-14020	1	
27	36	90209-14165	1	
27	37	521-25188-00	1	
27	38	91401-30030	1	
27	39	102-25137-00	1	
27	40	93210-14104	1	

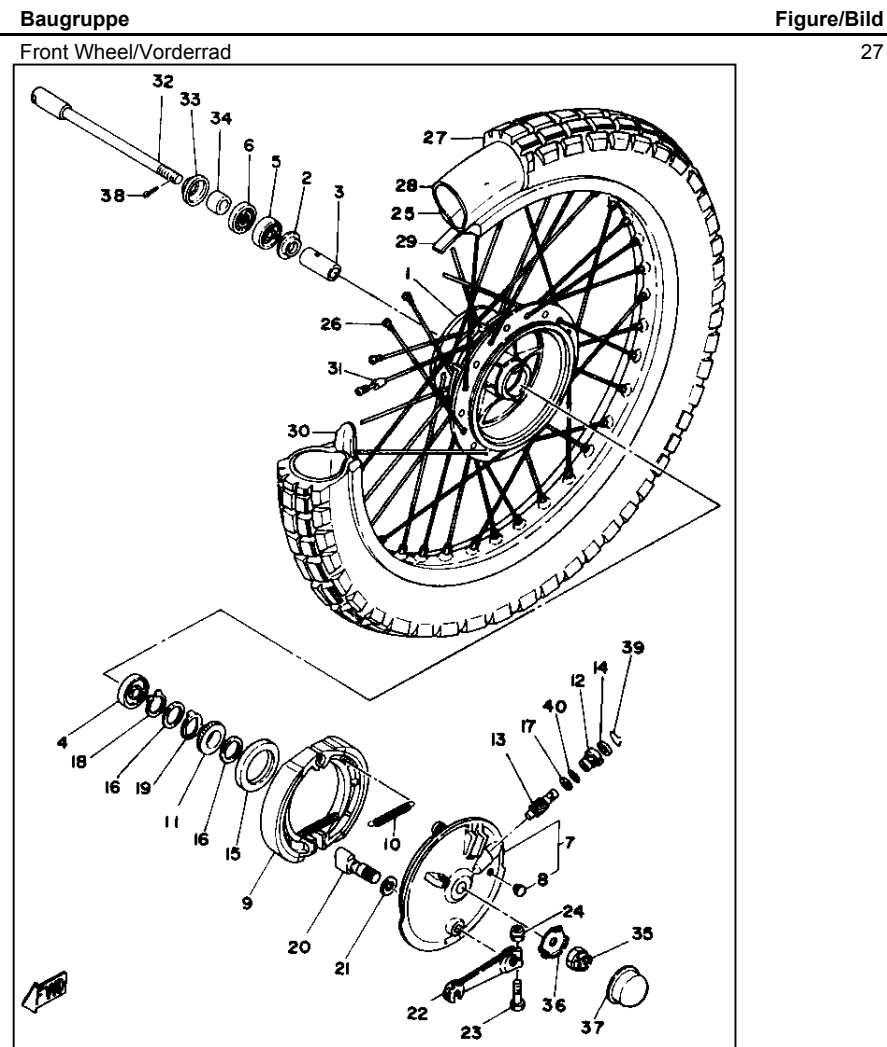

Fig. Pos.	Part No.	Description	Q'ty	Remark/Normteil/Maß
28	1	1E6-25311-00-98	HUB, rear	1 low gloss black
28	2	275-25317-00	SPACER, bearing	1
28	3	93306-20316	BEARING (B6203)	1
28	4	93306-20310	BEARING (B6203RS)	2
28	5	93102-25030	OIL SEAL	1
28	6	146-25315-00	FLANGE, spacer	1
28	7	1E6-25026-11-98	BRAKE SHOE PLATE ASSY	1 low gloss black
28	8	90480-10068	GROMMET	1
28	9	214-25130-00	BRAKE SHOE COMP.	2
28	10	90507-20002	SPRING, tension	2
28	11	3H7-25355-00	LEVER, camshaft	1
28	12	214-25351-01	CAMSHAFT	1
28	13	148-25353-00	SHIM, camshaft	1
28	14	148-25359-00	SEAL, camshaft	1
28	15	90101-06278	BOLT	1
28	16	95601-06100	NUT, u	1
28	17	1E6-25366-00-98	CLUTCH, hub	1 low gloss black
28	18	583-25442-10	SPROCKET, driven (42T)	1 UR STD
28	18a	583-25440-10	SPROCKET, driven (40T)	1 UR
28	18b	2H0-25444-20	SPROCKET, driven (44T)	1 UR
28	18c	583-25446-10	SPROCKET, driven (46T)	1 UR
28	19	90116-08218	BOLT, stud	6
28	20	583-25412-00	WASHER	3
28	21	90170-08193	NUT	6
28	22	93700-06004	NIPPLE, grease	1
28	23	1E6-25364-00	DAMPER	6
28	24	93210-52312	O-RING	2
28	25	93210-71311	O-RING	1
28	26	1E6-25318-00	STOPPER, hub	2
28	27	1E6-25319-01	SEAL, hub dust	1
28	28	93450-78080	CIRCLIP	1
28	29	1E6-25304-00	SPOKE SET, rear	1
28	30	94140-18204	TIRE (4.00-18)	1
28	31	94237-18120	TUBE (3.75-18)	1 bridgestone
28	32	94330-18087	BAND, rim (3.00-18)	1 bridgestone
28	33	1T2-25394-00	SPACER, bead	2
28	34	94418-18199	RIM (1.85-18)	1
28	35	150-25381-00	AXLE, wheel	1
28	36	90387-17141	COLLAR	1
28	37	90387-17530	COLLAR	1

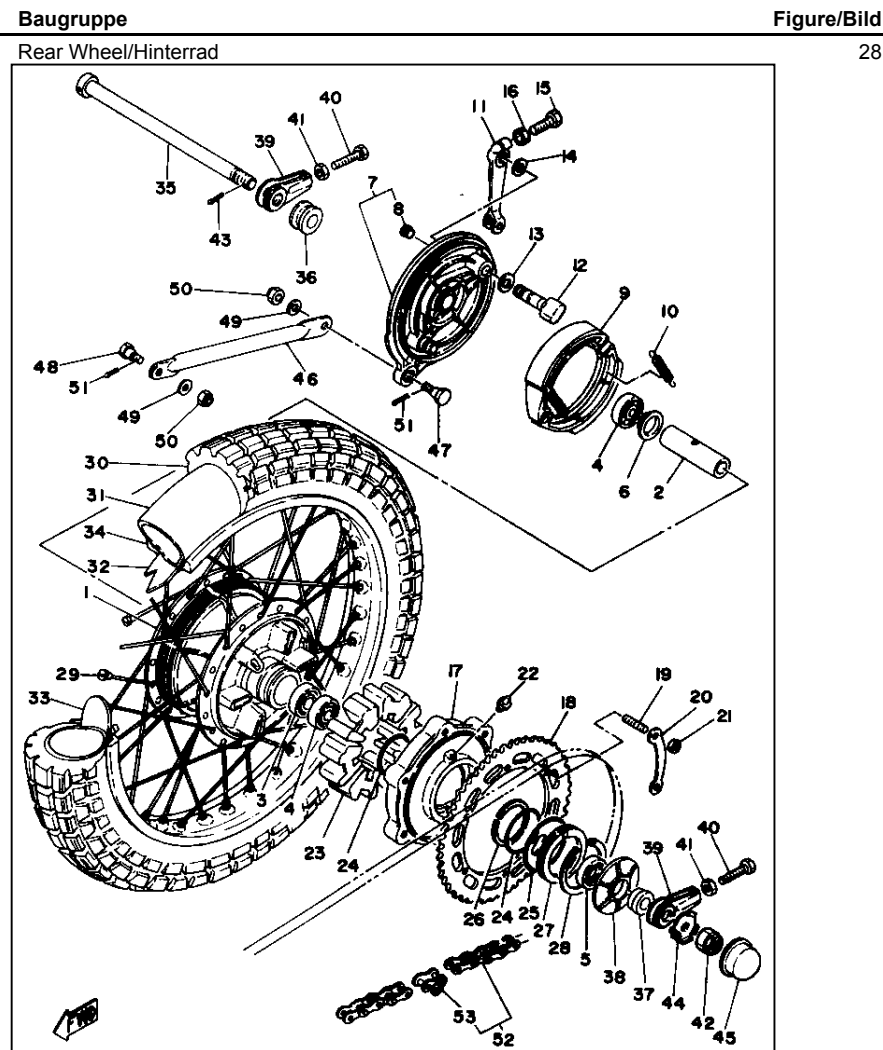

Fig. Pos.	Part No.	Description	Q'ty	Remark/Normteil/Maß	Baugruppe	Figure/Bild
28 38	1E6-25367-00	COVER, hub dust	1			
28 39	583-25388-00	PULLER, chain 1	2			
28 40	90101-08034	BOLT	2			
28 41	95301-08700	NUT	2			
28 42	90171-16021	NUT, castle	1			
28 43	91401-30030	PIN, cotter	1			
28 44	90209-16138	WASHER	1			
28 45	521-25188-00	CAP	1			
28 46	3H7-25371-00	BAR, tension	1			
28 47	90109-08406	BOLT	1			
28 48	90109-08368	BOLT	1			
28 49	92901-08200	WASHER, plain	2			
28 50	90185-08055	NUT, self-locking	2			
28 51	91401-20015	PIN, cotter	2			
28 52	94585-20100	CHAIN, drive (DID520DS 100L)	1			
28 53	94685-20011	JOINT, chain	1			

Fig. Pos.	Part No.	Description	Q'ty	Remark/Normteil/Maß	Baugruppe	Figure/Bild
29	1	3H7-26111-00	1	HANDLEBAR	Handlebar & Cable/Lenker, Kabel & Züge	29
29	2	583-26242-00	1	GRIP (R.H.)		
29	3	2H0-26243-00	1	TUBE, throttle guide		
29	4	1W1-26249-00	1	RING, leaf		
29	5	1E6-26241-00	1	GRIP (L.H.)		
29	6	2H0-26301-00	1	THROTTLE CABLE ASSY		
29	7	583-26398-00	1	WASHER		
29	8	90468-15009	1	CLIP		
29	9	3H7-26341-01	1	CABLE, brake		
29	10	1E6-26335-01	1	CABLE, clutch		
29	11	1E6-26342-00	1	BOOT, cable		
29	12	341-26397-01	1	BAND		
29	13	90123-08046	1	BOLT		
29	14	90179-08148	1	NUT		
29	15	1E6-26372-00	1	COVER, handle lever 1		
29	16	90123-08046	1	BOLT		
29	17	90179-08148	1	NUT		
29	18	1E6-26372-00	1	COVER, handle lever 1		
29	19	1E6-26331-00	1	CABLE, decompression		
29	20	583-26362-00	1	COVER, decompression Cable		
29	21	90338-09012	1	PLUG		
29	22	1Y1-26290-50	1	BACK MIRROR ASSY (L.H.)		
29	23	2X1-26124-00	1	PROTECTOR, handlebar		
29	24	437-83936-10	2	BAND, switch cord		

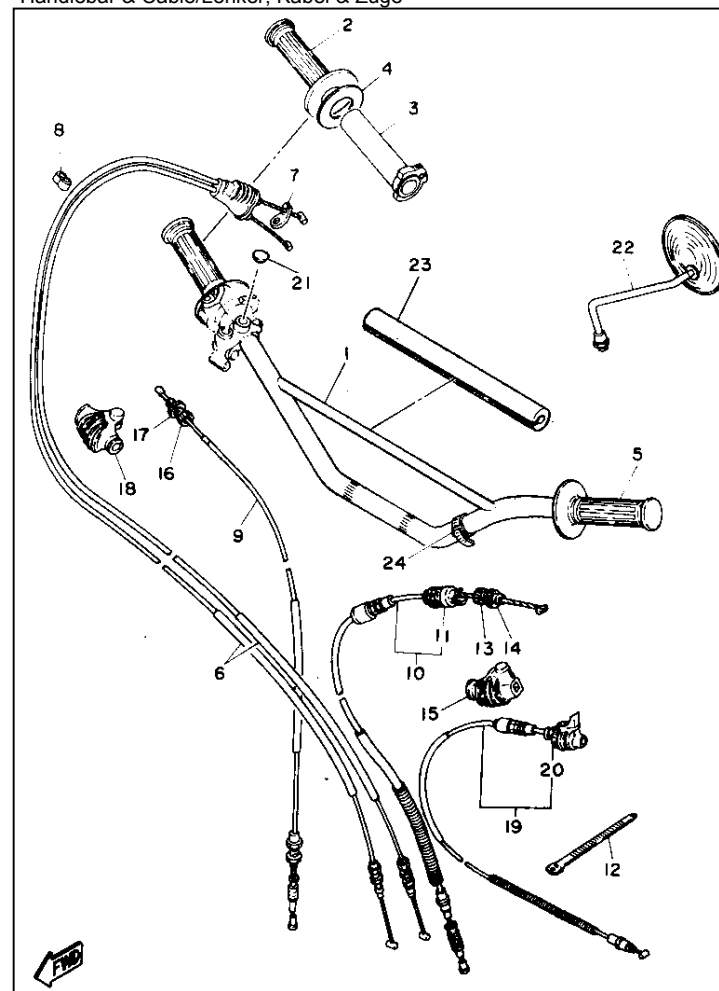

Fig. Pos.	Part No.	Description	Q'ty	Remark/Normteil/Maß
30	1	1U6-27211-00-R4	1	black
30	2	90109-06470	1	
30	3	92901-06100	1	
30	4	1E6-27252-00	1	
30	5	90508-32278	1	
30	6	498-27236-00	2	
30	7	583-27231-00	1	
30	8	583-27241-01	1	
30	9	90240-08061	2	
30	10	90201-08084	2	
30	11	91401-20015	2	
30	12	90501-10245	1	
30	13	90249-12008	1	
30	14	90175-06013	1	
30	15	1E6-27244-00	1	
30	16	90153-06008	1	
30	17	90170-06184	1	
30	18	2Y0-27412-00-33	1	
30	19	2Y0-27422-00-33	1	
30	20	1E6-27411-00	1	
30	21	1E6-27421-00	1	
30	22	214-27413-00	2	
30	23	90508-26277	1	
30	24	90508-26276	1	
30	25	97311-10016	2	
30	26	90201-10639	2	
30	27	91609-30020	2	
30	28	93700-06004	1	
30	29	4E5-27311-00-33	1	yamahablack
30	30	90109-10494	1	
30	31	90185-10037	1	
30	32	90507-26025	2	
30	33	90201-12631	2	
30	34	1U6-27315-00	2	

Baugruppe
Stand & Footrest/Ständer, Fußrasten & Bremsgestänge

Figure/Bild
30

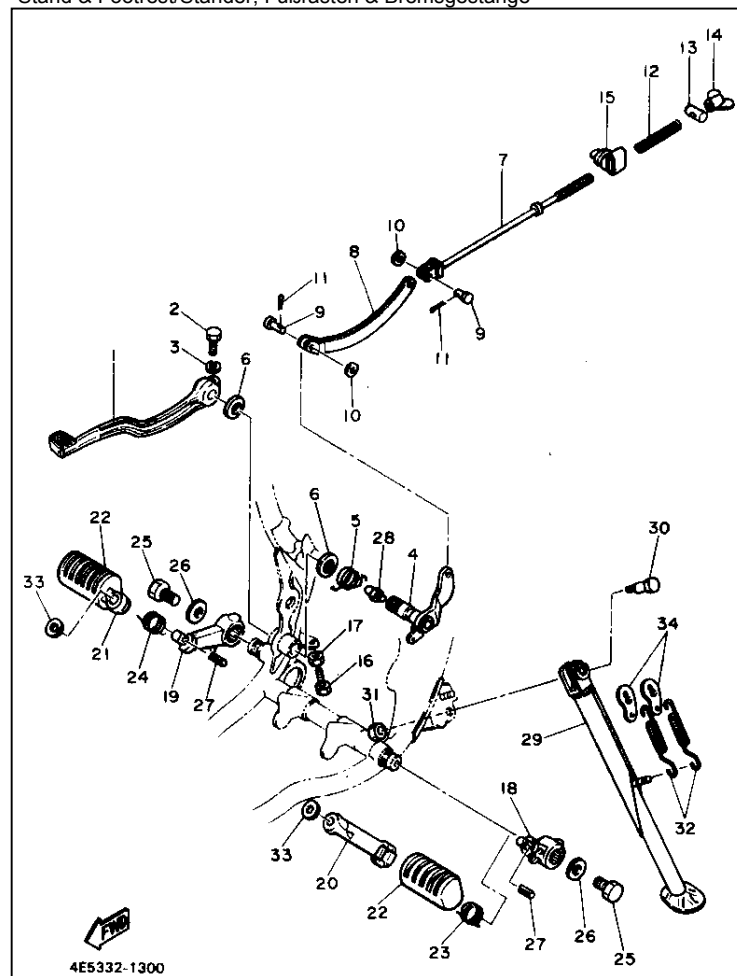

Fig. Pos.	Part No.	Description	Q'ty	Remark/Normteil/Maß
31	1	1U6-83310-45	2	FRONT FLASHER LIGHT ASSY 1
31	2	366-83312-40	1	LENS, flasher
31	3	1M1-83313-60	1	GASKET, flasher lens
31	4	1M1-83309-60	1	REFLECTOR
31	5	97701-30620	2	SCREW, Panhead tapping
31	6		2 LM	BULB (6V-21W)
31	7	1R6-83330-45	2	REAR FLASHER LIGHT ASSY 1
31	8	1M1-83309-60	1	REFLECTOR
31	9	1M1-83313-60	1	GASKET, flasher lens
31	10	366-83312-40	1	LENS, flasher
31	11	97701-30520	2	SCREW, Panhead tapping
31	12		2 LM	BULB (6V-21W)
31	13	92901-10100	2	WASHER, spring
31	14	90387-10403	2	COLLAR
31	15	95302-10600	2	NUT
31	16	1U6-83336-00	2	CORD
31	17	92901-10100	2	WASHER, spring
31	18	95302-10600	2	NUT
31	19	1U6-84544-00	2	COVER

Flasher Light/Blinker

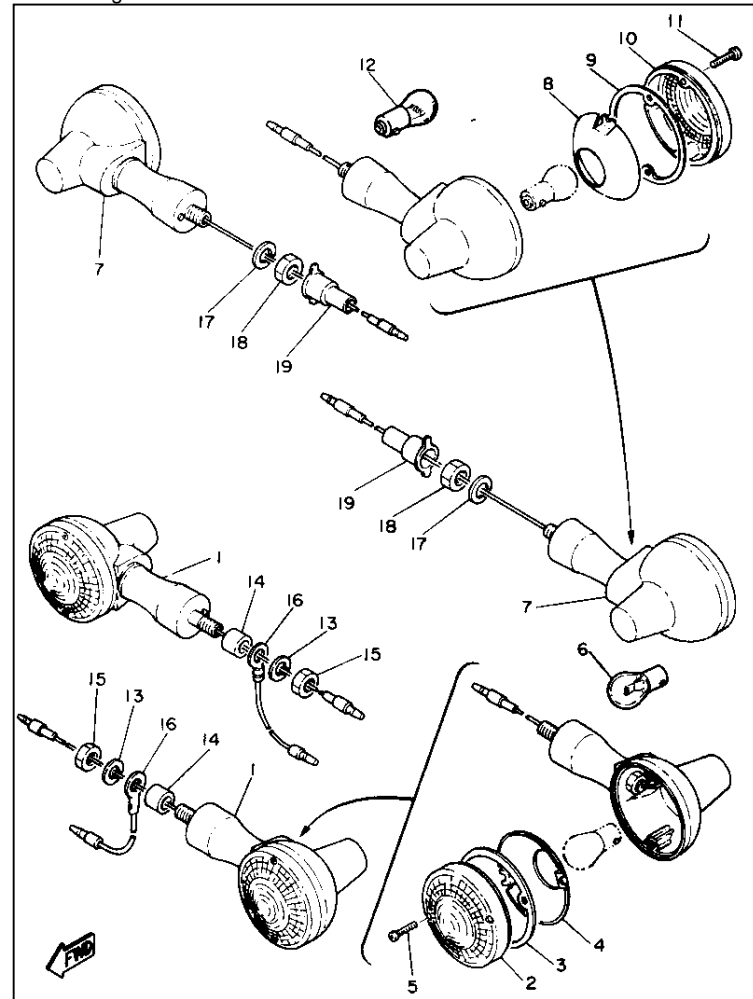

Fig. Pos.	Part No.	Description	Q'ty	Remark/Normteil/Maß
32	1	1E6-83570-F0	1	SPEEDOMETER ASSY
32	2	122-83516-10	1	BULB (6V-3W)
32	3	1E6-83536-60	1	SOCKET, meter
32	4	1E6-83578-10	1	KNOB, trip meter
32	5	1E6-83540-F1	1	TACHOMETER ASSY
32	6	122-83516-10	4	BULB (6V-3W)
32	7	1E6-83520-60	1	SOCKET CORD ASSY
32	8	1E6-83519-60	1	BRACKET, meter
32	9	97321-06035	2	BOLT
32	10	92901-06100	2	WASHER, spring
32	11	90201-06055	2	WASHER, plate
32	12	1E6-83523-60	2	DAMPER
32	13	1E6-83526-60	4	DAMPER 2
32	14	90201	4	WASHER, plate
32	15	95301-05800	4	NUT, crown
32	16	1E6-23445-00	2	DAMPER
32	17	3H6-83550-00	1	SPEEDOMETER CABLE ASSY
32	18	1E6-83560-52	1	TACHOMETER CABLE ASSY
32	19	102-25137-00	1	RING, stop
32	20	93210-14104	1	O-RING

Baugruppe
Speedometer & Tachometer/Drehzahlmesser & Tachometer

Figure/Bild

32

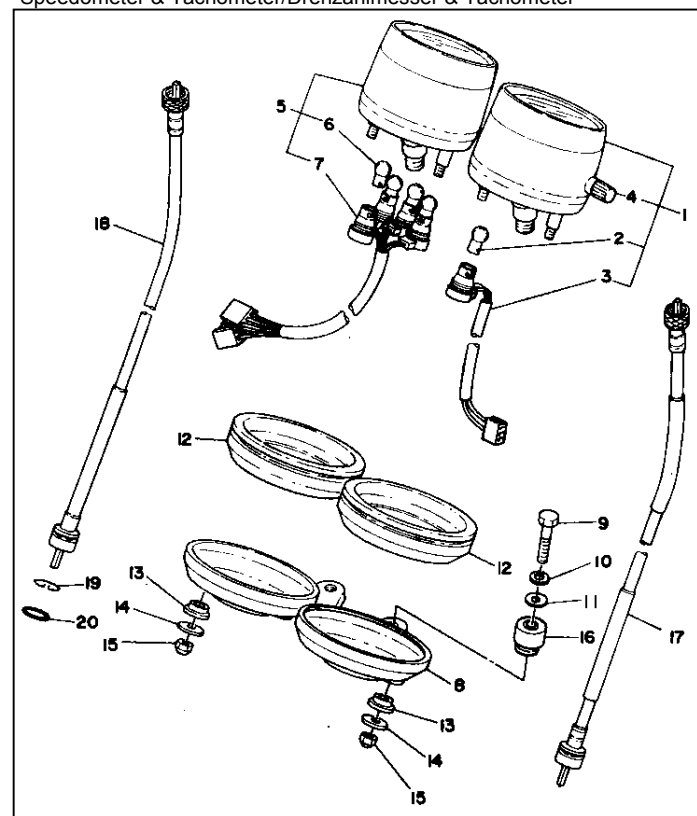

Fig. Pos.	Part No.	Description	Q'ty	Remark/Normteil/Maß
33	1	1R6-84103-45	1	HEADLIGHT UNIT ASSY
33	2	1N5-84115-20	1	RIM, headlight
33	3	456-84120-45	1	LENS ASSY
33	4	308-84124-20	3	SPRING, set
33	5	541-84112-40	1	SOCKET
33	6	308-84135-21	1	SPRING
33	7	457-84146-85	1	SOCKET, Pilot light
33	8		1 LM	BULB (6V-35/35W)
33	9		1 LM	BULB (6V-4W)
33	10	90152-05005	1	SCREW, countersunk
33	11	1U6-84130-45-33	1	BODY ASSY, headlight
33	12	1U6-84145-45	2	COLLAR, body fitting
33	13	1U6-84163-45	4	DAMPER
33	14	214-84153-60	1	GROMMET, wireherness
33	15	97303-08040	2	BOLT
33	16	92901-08200	4	WASHER, plain
33	17	92901-08100	2	WASHER, spring
33	18	95301-08600	2	NUT

Baugruppe
Headlight/Scheinwerfer

Figure/Bild
33

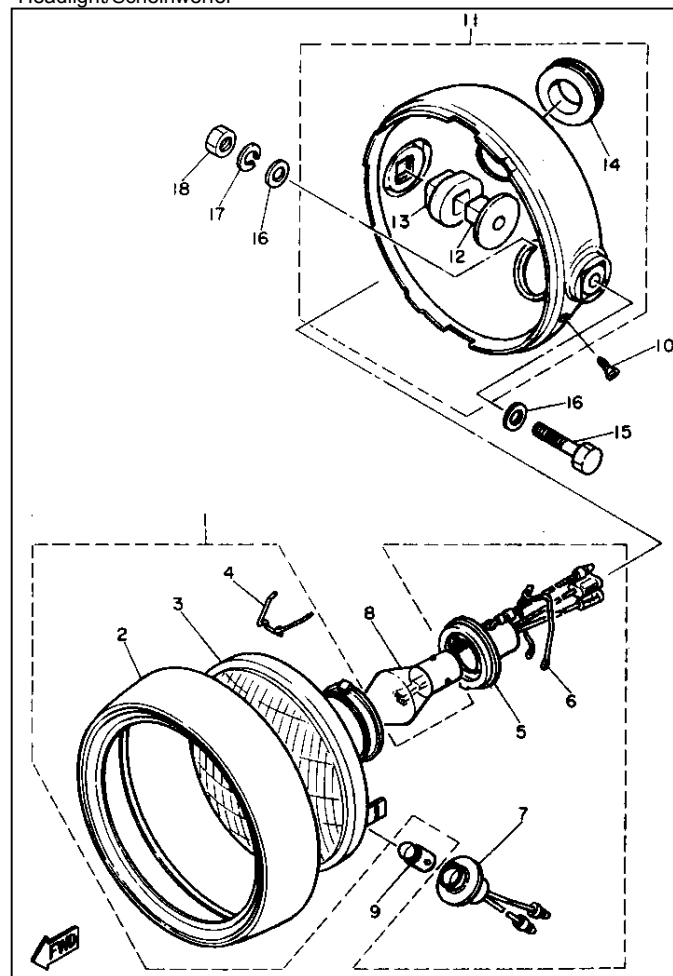

Fig. Pos.	Part No.	Description	Q'ty	Remark/Normteil/Maß	Baugruppe
34	1	1U6-84510-40	1		Taillight & License Plate/Rücklicht & Kennzeichenhalter
34	2	1U6-84511-40	1		
34	3	1M8-84514-41	1		
34	4	275-84523-60	1		
34	5	456-84521-22	1		
34	6	341-84724-60	3		
34	7	341-84722-60	3		
34	8	278-84718-40	1		
34	9	437-84527-60	1		
34	10	479-84526-00	2		
34	11	2H7-84754-00	2		
34	12	275-84627-60	2		
34	13	1U6-84551-40-33	1	YAMAHA black	
34	14	1E6-21638-00	2		
34	15	97301-06030	1		
34	16	90201-06073	1		
34	17	90201-06061	1		
34	18	92901-06100	1		
34	19	95301-04800	1		
34	20	90387-07598	1		
34	21	1U6-84553-00	1		
34	22	90109-08022	2		
34	23	92901-06100	2		
34	24	90209-08125	2		
34	26	95301-06600	2		
34	26	1U6-84517-00	1		
34	27	90480-15061	2		
34	28	1U6-21681-01	1		
34	29	1U6-21682-00	1		
34	30	90480-12188	1		
34	31	90387-06638	1		
34	32	97301-06020	3		
34	33	92901-06100	3		
34	34	90201-06055	5		
34	35	90201-06407	1		
34	36	95301-06600	3		
34	37	1U6-21641-00	1		
34	38	97301-06012	2		
34	39	92901-06600	2		
34	40	90201-06055	2		

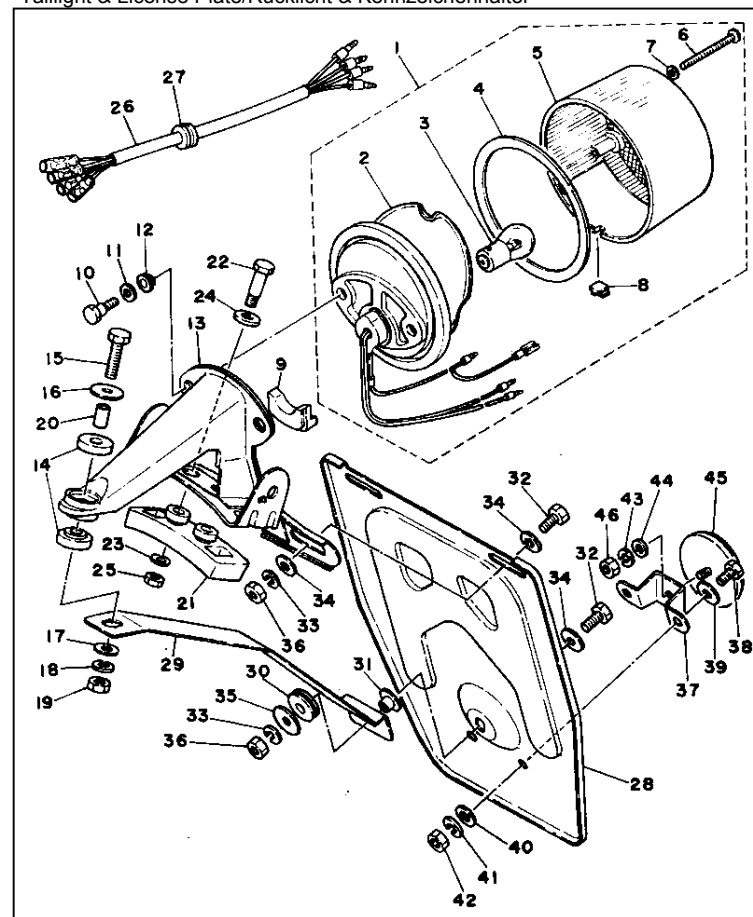

Fig. Pos.	Part No.	Description	Q'ty	Remark/Normteil/Maß	Baugruppe	Figure/Bild
34 41	92901-06100	WASHER, spring	2			
34 42	95301-06600	NUT	2			
34 43	92902-05100	WASHER, spring	1			
34 44	92901-05600	WASHER, plate	1			
34 45	449-85131-01	REFLECTOR, rear 1	1			
34 46	96302-05600	NUT	1			

Fig. Pos.	Part No.	Description	Q'ty	Remark/Normteil/Maß
35	1	363-81970-63	RECTIFIER ASSY	1 UR
35		353-81970-50	RECTIFIER ASSY	1 UR
35	2	98501-05016	SCREW, pan head	1
35	3	92901-05600	WASHER, plate	1
35	4	1E6-81910-62	VOLTAGE REGULATOR ASSY	1
35	5	92501-06015	SCREW, pan head	2
35	6	92901-06100	WASHER, spring	2
35	7	92901-06600	WASHER, plate	2
35	8	1E6-81949-00	WIRE, lead	1
35	9	1E6-82110-29	BATTERY ASSY (6N6-3B-1)	1
35	10	1E6-82131-00	BAND, battery	1
35	11	1E6-82122-01	SEAT, battery	1
35	12	90446-08433	HOSE	1
35	13	1E6-82150-00	FUSE HOLDER ASSY	1
35	14	1E6-82151-00	FUSE (6V-10A)	2 2
35	15	2H1-82508-20	MAIN SWITCH ASSY	1
35	16	2H1-82556-00	DAMPER, main switch 1	1
35	17	526-82579-00	CAP, key	2
35	18	437-82556-00	DAMPER, main switch	2
35	19	437-82516-00	COLLAR, main switch	2
35	20	90201-05031	WASHER, plate	2
35	21	98501-05025	SCREW, pan head	2
35	22	92901-05100	WASHER, spring	2
35	23	2H1-82590-40	WIRE HARNESS ASSY	1
35	24	538-82599-10	COVER, connector	2
35	25	583-82310-50	IGNITION COIL ASSY	1
35	26	92501-06025	SCREW, pan head	2
35	27	92901-06600	WASHER, plate	2
35	28	512-82370-10	PLUG CAP ASSY	1 UR with noise suppresser
35	28a	808-82370-10	PLUG CAP ASSY	1 UR
35	29	90465-10018	CLAMP	1
35	30	90465-10090	CLAMP	1
35	31	437-83936-00	BAND- switch cord	6
35	32	1E6-82116-00	WIRE, minus lead	1
35	33	366-82591-00	BAND	1
35	34	90446-07114	HOSE	1
35	35	1E6-82129-00	COVER, battery	1
35	36	90465-08028	CLAMP	1
35	37	92501-06014	SCREW, pan head	1
35	38	92901-06100	WASHER, spring	1

Baugruppe
Electrical 1/Elektrik 1 (Kabelbaum, Batterie etc.)

Figure/Bild

35

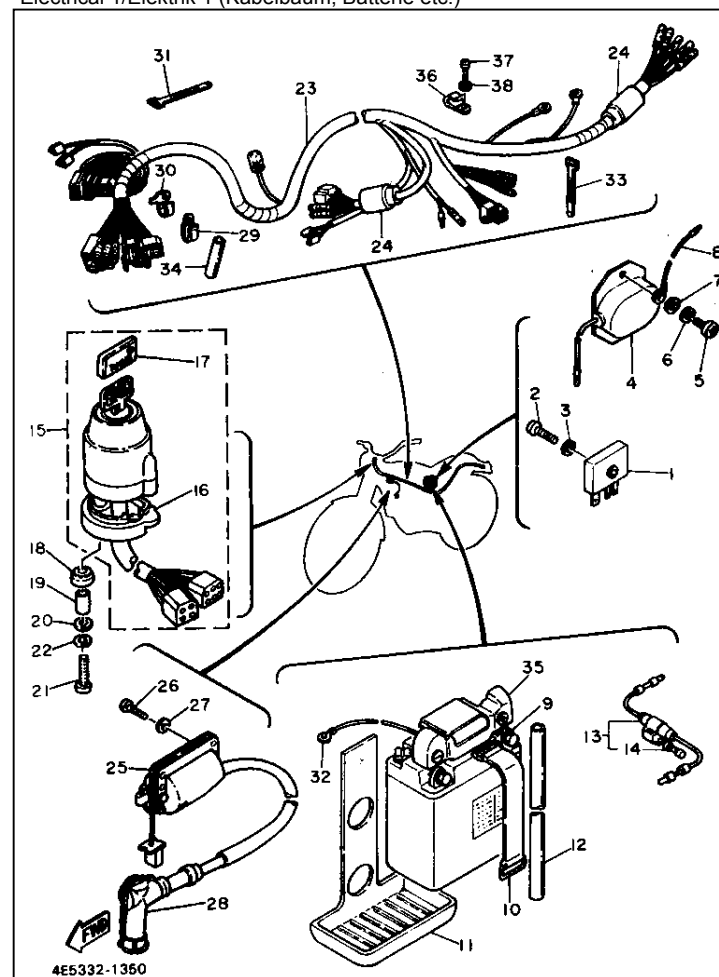

Fig. Pos.	Part No.	Description	Q'ty	Remark/Normteil/Maß	Baugruppe	Figure/Bild
36	1	1T2-82530-00	1		Electrical 2/Elektrik 2 (Hupe, Leerlaufschalter, Blinkrelais etc.)	36
36	2	2H7-82540-00	1			
36	3	90430-10148	1			
36	4	420-83350-30	1			
36	5	3H7-83371-00	1			
36	6	97301-08012	1			
36	7	92901-08100	1			

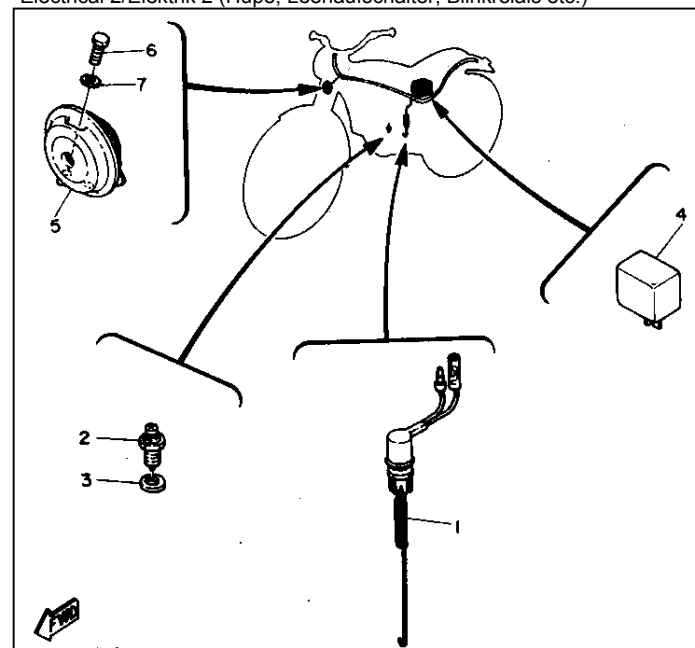

Fig. Pos.	Part No.	Description	Q'ty	Remark/Normteil/Maß
37	1	583-82911-01-98	1	low gloss black
37	2	2H0-83912-20	1	low gloss black
37	3	90109-06410	2	
37	4	95601-06100	2	
37	5	97301-06022	2	
37	6	92901-06100	2	
37	7	583-83981-00	1	
37	8	583-83913-00	1	
37	9	98501-05018	1	
37	10	95601-05100	1	
37	11	2H0-83922-20	1	low gloss black
37	12	361-82921-31	1	
37	13	361-83980-30	1	
37	14	90201-08083	2	
37	15	1E6-83976-00	1	
37	16	98506-05018	2	
37	17	1R7-83972-00	1	
37	18	98506-05025	1	
37	19	98506-05030	1	

Baugruppe Handle Switch & Lever/Lenkerschalter & Hebel Figure/Bild 37

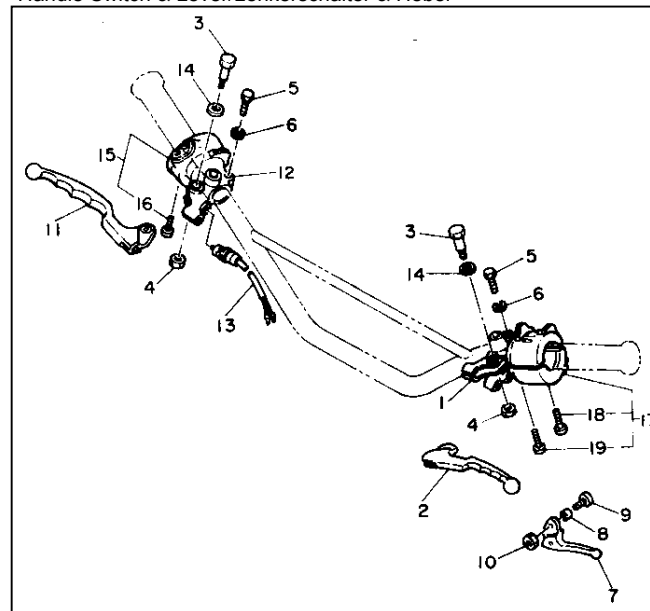

Fig. Pos.	Part No.	Description	Q'ty	Remark/Normteil/Maß	Baugruppe	Figure/Bild
38	1	1Y1-26290-60	1		Right Backmirror/Rechter Rückspiegel	38

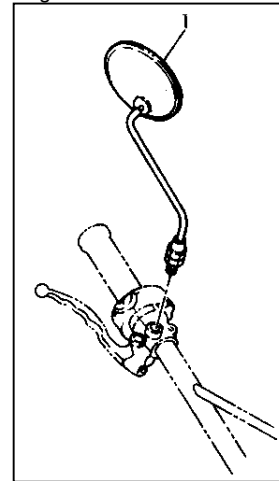

Fig. Pos.	Part No.	Description	Q'ty	Remark/Normteil/Maß	Baugruppe	Figure/Bild
-----------	----------	-------------	------	---------------------	-----------	-------------

Legende:

UR	Use size or number as required	=	Größe oder Menge nach Bedarf
UN	Use as many as you need	=	Menge nach Bedarf
AP	Alternate Parts	=	alternative Teile
LM	Local Made	=	i.d.R. Landesspezifisch